

IDBI Junior Assistant Manager Previous Year Paper (March 2024)

Directions (1-5): Study the following information carefully and answer the following questions carefully.

Nine persons – R, S, T, U, V, W, X, Y and Z, are sitting in a row facing the north. There are twelve chairs in the row, where three chairs are vacant. Neither the chairs at the end nor the adjacent chairs are vacant. Chairs are marked 1 to 12 from left to right. Only one chair in an odd position is vacant.

T is sitting at the fifth chair from the left end. Three persons are sitting between T and Z. Neither Z nor S are sitting at the end. V is sitting at an even number chair. R is sitting at third chair to the left of V but none of them is sitting at the end. Only two vacant chairs are placed between R and S. Both S and U are sitting adjacent seat to neither Z nor V. One person is sitting between V and X who is sitting to the right of S. Two persons are sitting between U and V. U is not sitting adjacent to the vacant chair. Y and Z are not sitting together.

Q1. How many persons are sitting between R and Z?

- (a) Three
- (b) Four
- (c) One
- (d) Two
- (e) None of these

Q2. Which of the following statement is not true?

- (a) U sits third to the left of T
- (b) Two persons are sitting between W and S
- (c) Z sits second to the right of S
- (d) Four persons are sitting to the left of V
- (e) All the above statements are true

Q3. Who among the following person sits immediate right of T?

- (a) The one who sits third to the left of Z
- (b) W
- (c) V
- (d) U
- (e) None of these

Q4. What is the position of X with respect to T?

- (a) Second to the right
- (b) Third to the left
- (c) Immediate left
- (d) Fourth to the right
- (e) None of these

Q5. Which of the following person sits adjacent to the vacant chair?

- I. U, V and X
- II. R, T and Z
- III. Y, T and Z
- (a) Only II
- (b) Both II and III
- (c) Only I
- (d) Both I and II
- (e) None of these

Directions (6-10): Study the following information carefully and answer the questions given below.

Eight persons i.e. A, B, C, D, E, F, G and H live in two different flats i.e., Flat P and Flat Q of a four-floor building such that the lowermost floor is numbered as 1 and the floor just above it is numbered as 2 and so on till the topmost floor is numbered as 4. Flat P is to the west of flat Q whereas flat P of floor 2 is immediately above flat P of floor 1 and flat Q of floor 2 is immediately above flat Q of floor 1. Each of them likes different musical instruments- Guitar, Piano, Sitar, Flute, Drum, Cello, Violin and Harp but not necessarily in the same order.

The one who likes Guitar lives two floors above the one who likes Drum. The one who likes drum lives on an even numbered floor. E lives to the north-east of F and lives below the one who likes Guitar. D lives to the south of F. A and C live on the same floor. The one who likes sitar lives to the east of A. B lives immediately above G's flat. The one who likes violin lives to the east of H. The one who likes Harp lives two floors above the one who likes Piano. The one who likes flute lives to the west of the one who likes Piano. B doesn't like Cello.

Q6. Who among the following likes Sitar?

- (a) None of these
- (b) B
- (c) C
- (d) D
- (e) F

Q7. Which among the following pair of persons live in the same flat?

- (a) The one who likes Harp, B
- (b) The one who likes Violin, D
- (c) A, B
- (d) F, the one who likes Piano
- (e) H, the one who likes flute

Q8. In which among the following floor and flat does B live?

- (a) Floor 2, flat P
- (b) Floor 3, flat P
- (c) Floor 3, flat Q
- (d) Floor 2, flat Q
- (e) Floor 4, flat Q

Q9. Which among the following statement is not true?

- (a) D lives on the bottom most floor.
- (b) The sum of the floors of G and A is an odd number
- (c) C lives in flat Q
- (d) No one lives to the east of the one who likes Violin
- (e) F doesn't like Cello

Q10. Which among the following combination is correct?

- (a) H- 4th floor
- (b) C- Flat P
- (c) G- Piano
- (d) D- Cello
- (e) A- 3rd floor

Directions (11-15): Each of the questions below, consist of a question and three statements numbered I, II and III given below it. You have to decide whether the data given in the statements are sufficient to answer the question or not. Read all statements and give answer.

Q11. Seven persons sit around a circular table such that all of them face away from the center. Who among the following sits third to the left of C?

I. G sits two persons away from A. B sits adjacent to both E and G. D sits two persons away from B. C sits adjacent to F.

II. Three persons sit between E and A. D sits adjacent to A. F sits two persons away from the one who sits adjacent to C.

III. Only two persons sit between A and E who doesn't sit adjacent to G. F sits second to the right of D.

- (a) Both statements I and II are sufficient to answer
- (b) Both statements I and III are sufficient to answer
- (c) Both statements II and III are sufficient to answer
- (d) Statement II alone is sufficient to answer
- (e) Statements I, II and III even together are not sufficient to answer

Q12. Seven persons live in seven floor building such that the bottommost floor is numbered as 1, floor just above it is numbered as 2 and so on till the topmost floor is numbered as 7. How many persons live between R and S?

I. S lives on an even numbered floor below T. As many persons live above P as below the one who lives two floors above U.

II. Only three persons live between P and S. T lives two floors above V. U lives on the bottommost floor. R lives above Q but not adjacent to S.

III. S lives on an even numbered floor. T lives on a prime numbered floor. Only two persons live between U and Q.

- (a) Both statements II and III are sufficient to answer
- (b) Both statements I and III are sufficient to answer
- (c) All statements I, II and III are sufficient to answer
- (d) Statement II alone is sufficient to answer
- (e) Statements I, II and III even together are not sufficient to answer

Q13. From which of the following statement, the given conclusion “Some Toyota being Nissan is a possibility” follows?

- I. All Audi is Toyota. Some Audi is Nissan. No Nissan is Thar. Only a few Thar is Bentley.
- II. Only a few Thar is Audi. All Audi is Toyota. Some Toyota is Bentley. No Nissan is Bentley.
- III. All Toyota is Bentley. No Bentley is Nissan. Only a few Nissan is Audi. Some Thar is not Audi.

- (a) Either statement I or II are sufficient to answer
- (b) Either statement I or III are sufficient to answer
- (c) Statement I alone is sufficient to answer
- (d) Statement II alone is sufficient to answer
- (e) Statement III alone is sufficient to answer

Q14. Nine persons sit around a triangular table such that three of them sit at the corner and the two persons sit at each side of the table. All of them face towards the center. Who among the following sits fourth to the left of I?

- I. J sits third to the left of H. Only two persons sit between D and H. F sits adjacent to the one who sits next to B.
- II. B sits adjacent to both J and E. Only two persons sit between J and D. I doesn't sit at the corner of the table.
- III. B and E sit adjacent to each other. C sits third to the right of B. The one who sits adjacent G sits two persons away from I

- (a) Both statements I and II are sufficient to answer
- (b) Both statements I and III are sufficient to answer
- (c) All statements I, II and III are sufficient to answer
- (d) Statement II alone is sufficient to answer
- (e) Statements I, II and III even together are not sufficient to answer

Q15. Seven persons of different heights are arranged in descending order from left to right. Who is the second tallest among all?

- I. P is taller than Q but shorter than S. U is not the tallest among all. R is just taller than V. Q is taller than R.
- II. S is taller than T and U. U is taller than at least two persons. P's height is twice of S's height but he is not the tallest among all.
- III. Q is taller than R but shorter than P. T is just shorter than P. Only two persons are between S and Q. V is shorter than R and S. U is shorter than S but taller than R.

- (a) Both statements I and II are sufficient to answer
- (b) Both statements I and III are sufficient to answer
- (c) Both statements II and III are sufficient to answer
- (d) Statement II alone is sufficient to answer
- (e) Statement III alone is sufficient to answer

Directions (16-19): In each of the question below, some statements are given followed by some conclusions. You have to take the given statements to be true even if they seem to be at variance with commonly known facts. Read all the conclusions and then decide which of the given conclusions logically follows from the given statements disregarding commonly known facts.

Q16. Statements: Some tree is leaf.

Only leaf is sky.

Only a few land is leaf.

All land is seed.

Conclusions:

(a) No sky being seed is a possibility.

(b) Some seed will not be leaf.

(c) Some tree is not land.

(d) All tree is seed.

(e) All sky is land.

Q17. Statements: Only soft is music.

All genius are soft.

No papaya is soft.

All boys are genius.

Conclusions:

(a) No genius is music.

(b) All boys are music.

(c) Some papaya can be genius.

(d) Some music not being papaya is a possibility.

(e) Some soft not being music is a possibility.

Q18. Statements: All board is screen.

No game is digital.

Only a few cheque is digital.

Some digital is not board.

Conclusions:

(a) Some screen is not cheque.

(b) No board is cheque.

(c) All game can never be board.

(d) Some cheque is not board.

(e) All cheque can never be digital.

Q19. Statements: All space is arrow.

No space is mark.

Only a few mark are exam.

Only a few mark are lock.

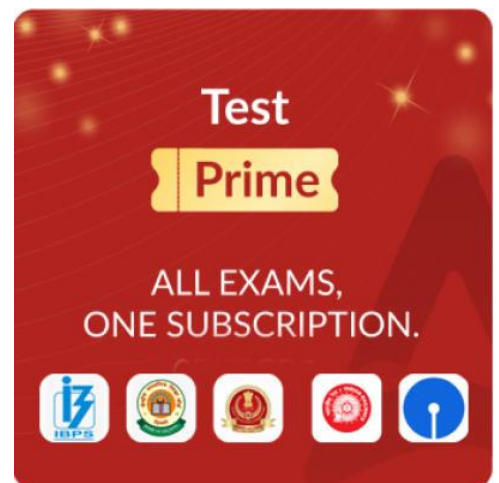

Test
Prime

ALL EXAMS,
ONE SUBSCRIPTION.



Conclusions:

- (a) All exam is space.
- (b) No lock is space.
- (c) All marks can be exam.
- (d) Some arrow can be mark.
- (e) Some arrow is not lock.

Q20. In the given number '58763423', if 1 is subtracted from the first half digits second half of the digits are multiplied by 2 after that all the digits are arranged in descending order from right to left. Then, what will be the sum of all the digits at the even place from the left end of the new number formed after rearrangement?

- (a) 23
- (b) 25
- (c) 24
- (d) 26
- (e) None of these

Directions (21-25): A number and word arrangement machine when given an input line of words and numbers rearranges them following a particular rule in each step. The following is an illustration of input and rearrangement:

Input: 59 Permanent 72 Various 45 Particulars 64 Abacus 82 Geometry

Step I: 72 59 Permanent Various 45 64 Abacus 82 Geometry Particulars

Step II: 82 72 59 Various 45 64 Abacus Geometry Particulars Permanent

Step III: 45 82 72 59 Various 64 Abacus Particulars Permanent Geometry

Step IV: 64 45 82 72 59 Abacus Particulars Permanent Geometry Various

Step V: 59 64 45 82 72 Particulars Permanent Geometry Various Abacus

Step V is the last step of the given arrangement. Based on its logic, rearrange the given input.

Input: 66 sanctions 77 flouting 55 reforms 83 anniversary 43 revolution

Q21. Which among the following element is third to the left of second element from the right end in step III?

- (a) 66
- (b) Anniversary
- (c) Flouting
- (d) 77
- (e) Reforms

Q22. How many letters according to the alphabetical series are between the third letter of the second word from the right end and second letter of the first word from the left end in step IV?

- (a) 9
- (b) 8
- (c) 6
- (d) 7
- (e) 5

Q23. In which among the following step, the order “55 83 43 anniversary revolution sanctions” remains same?

- (a) Step I
- (b) Step II
- (c) Step III
- (d) Step V
- (e) Step IV

Q24. What is the product of the number which is third from the left end in step III and the number which is second from the right end in step I?

- (a) 2365
- (b) 3215
- (c) 2114
- (d) 1345
- (e) 6235

Q25. What is the sum of the elements which are second, third and fifth from the left end in step II?

- (a) 166
- (b) 136
- (c) 231
- (d) 236
- (e) 186

Directions (26-30): Read the following information and answer the questions that follow:

Eight members Ravi, Diya, Arti, Paras, Palak, Suresh, Tanmay and Ganesh are in the family of three generation. They are sitting around a circular table in a restaurant facing to the centre and order different dishes viz. Aloo paratha, Baingan bharta, Chana masala, Doughy, Empanadas, Fish curry, Gumbo and Hamburger but not necessarily in the same order. Also, they speak three languages i.e., Hindi, English and Spanish. At least two persons speak same language and not more than three persons speak same language. Ganesh speaks the same language as Tanmay who sits third to the left of Diya's brother and fourth to the right of Diya. Diya's grandson is sitting exact opposite of Diya's daughter-in-law who orders Fish curry. Diya's son (except Ganesh) orders Chana masala while Diya orders Doughy and speaks English language. Diya has two grandchildren and two sons. Only Arti and Palak speak Hindi language. Ravi's brother-in-law orders Hamburger and speaks Spanish language. Suresh is the maternal uncle of Tanmay. Tanmay's brother orders Aloo paratha. Ravi has two sons. The Persons who order Empanadas and Doughy speak English language. Arti is the mother of Palak and sits third to the right of Palak. Ganesh's father orders Gumbo and speaks English language also sits immediate right of Palak who is sister of Paras. Ganesh is brother of Tanmay and Paras is grandson of Diya. Paras's father sits immediate left of Diya's daughter-in-law.

Q26. How many persons sit between Palak and the one who orders Hamburger when counted from the right of Palak?

- (a) Five
- (b) Three
- (c) Two
- (d) One
- (e) None of these

Q27. Which of the following information is incorrect?

- I. Tanmay does not speak English
 - II. Ravi is the father of Palak
 - III. Suresh order empanadas
- (a) Both II and III
 - (b) Only III
 - (c) Both I and II
 - (d) Only II
 - (e) All are incorrect

Q28. If all the persons sit according to the alphabetical order in clockwise direction from Arti, then how many persons remain unchanged (Excluding Arti)?

- (a) Four
- (b) Three
- (c) More than four
- (d) One
- (e) None

Q29. What is the position of Arti's brother-in-law with respect to Tanmay's uncle?

- (a) Immediate right
- (b) 3rd to the left
- (c) 7th to the right
- (d) 6th to the left
- (e) 2nd to the right

Q30. Four of the following five are alike in a certain way and hence form a group. Who among the following does not belong to that group?

- (a) Ganesh
- (b) Suresh
- (c) Tanmay
- (d) Paras
- (e) Diya

Directions (31-35): Study the following information carefully and answer the questions given below:

Anil starts walking in the east direction and reached at point A after walking 15m. From point A he turns towards the right and walks 8m to reach point B. From point B he turns towards the left and walks 7m to reach point C. From point C he moves towards the south direction and walks 6m to reach point D. Vinay starts walking towards the west and reached at point I after walking 6m. From point I he turns towards the left and walks 10m reached at point H. From point H he moves towards the west and reached point G after walking 7m. From point G he turns towards left and walks 4m to reach point E. From point E he turns toward the west to reach at point D after walking 5m.

Q31. What is the direction of point A with respect to point E?

- (a) North
- (b) North-east
- (c) North-west
- (d) West
- (e) None of these

Q32. What is the total distance between point B and point H?

- (a) 34m
- (b) 29m
- (c) 32m
- (d) 28m
- (e) None of these

Q33. Which among the following point is in the west of Vinay's starting point?

- (a) Point B
- (b) Point E
- (c) Point C
- (d) Point A
- (e) None of these

Q34. What is the shortest distance between Anil's starting point and point B?

- (a) 18m
- (b) 16m
- (c) 17m
- (d) 19m
- (e) None of these

Q35. If in the given word “INCANDESCENT”, all the vowels are changed with the third succeeding letter and all the consonants are changed with second preceding letter then all the letters are arranged in alphabetical order from left to right then how many letters are between the third letter from the right end and fourth letter from the left end (according to alphabetical series)?

- (a) Seven
- (b) Eight
- (c) Six
- (d) Nine
- (e) Five

Directions (36-40): Study the following information carefully to answer the given questions:

Ten persons are sitting in two parallel rows containing five person each, in such a way that there is an equal distance between adjacent persons. In row-1 M, N, O, K and L are seated and all of them are facing south. In row-2 U, V, W, X and Y are seated and all of them are facing North. Therefore, in the given seating arrangement each member seated in row 1 faces another member of the row 2. Five of them like flowers i.e., Rose, Lotus, Orchid, Sunflower and Lily and the remaining five like fruits i.e., Mango, Guava, Kiwi, Apple and Pears. No two adjacent persons like the same things (either flower or fruits).

O likes mango and sits third to the left of N who likes lotus. Only one person sits between O and M. X faces the one who sits second to the left of the one who likes lotus. The one who likes rose faces the one who sits third to the right of the one who likes lily. The one who likes lily faces north. The one who likes kiwi faces the one who sits third to the left of Y. Y likes fruit and sits at one of the extreme ends. The one who likes orchid faces the one who sits second to the right of the one who likes guava. Y doesn't like apple. U likes flower but not lily. W sits second to the left of the one who faces K.

Q36. Who among the following likes rose?

- (a) V
- (b) K
- (c) The one who sits at immediate left of O
- (d) The one who faces X
- (e) None of these

Q37. How many persons are sitting between N and the one who likes mango?

- (a) One
- (b) Two
- (c) Three
- (d) None of these
- (e) None

Q38. Four of the following five are alike in a certain way and hence form a group, which of the following does not belong to the group?

- (a) M
- (b) N
- (c) O
- (d) L
- (e) V

Q39. Which of the following statement is not true?

- (a) N sits at one of the extreme ends
- (b) O sits at immediate right of L
- (c) X sits at exactly between W and Y
- (d) V likes pears
- (e) All are true

Q40. Who among the following sits third to the right of the one who faces Y?

- (a) The one who likes kiwi
- (b) K
- (c) N
- (d) Both (a) and (c)
- (e) The one who likes orchid

Directions (41-45): The line graph shows the total number of students in four different sections (A, B, C and D) of 10th class. It also shows the percentage of number of students went on a trip out of the total students in each section. Read the data carefully and answer the following questions.

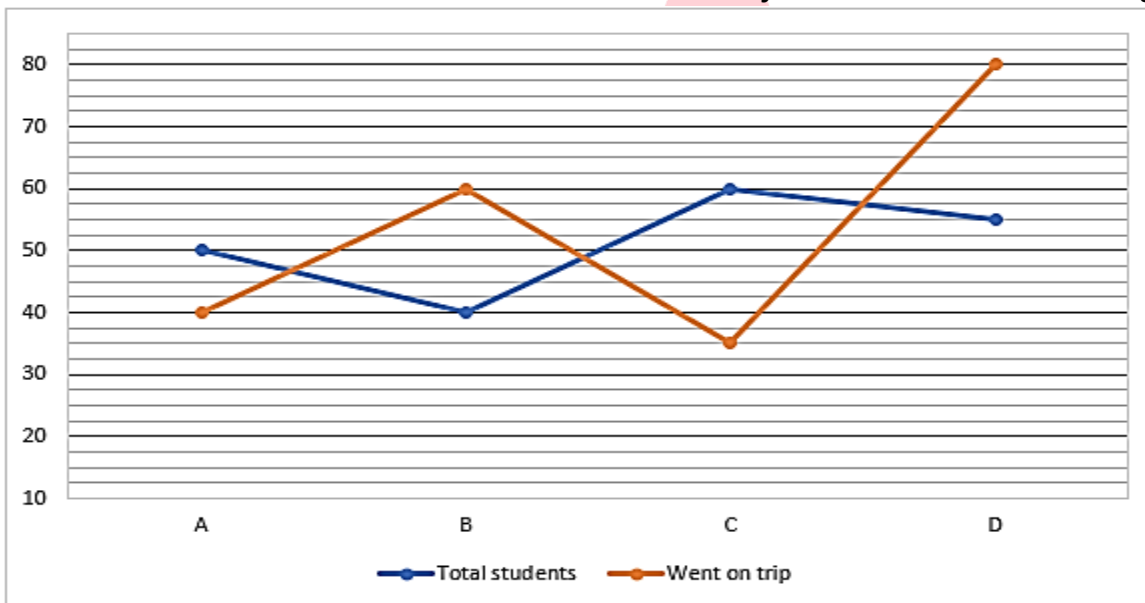

Note: Total number of Students = students who went on a trip + who did not went on a trip

Q41. Find the ratio of the number of students went on a trip from B and D together to the number of students did not go on a trip from A and D together.

- (a) 67:41
- (b) 68:41
- (c) 68:43
- (d) 63:47
- (e) 33:40

Q42. The ratio of boys to girls in the section A and D is 2: 3 and 5: 6 respectively. If 10 boys from section A and 25 girls from section D went on a trip, then find the number of boys from both the section who did not go on a trip.

- (a) 15
- (b) 13
- (c) 16
- (d) 18
- (e) 10

Q43. Find the average number of students did not go on the trip from all the sections.

- (a) 24
- (b) 25
- (c) 28
- (d) 20
- (e) 21

Q44. Ratio of boys and girls who did not go on a trip from section A, B and D is 3: 2 , 1:3 and 5: 6 respectively. If the total number of boys who did not go on a trip is 54, then find the number of girls who did not go on the trip from C.

- (a) 10
- (b) 15
- (c) 14
- (d) 12
- (e) 18

Q45. Difference between the boys and girls in section A is 10 and in section C is 20. If 30% of boys went on a trip is from section A and 40% of girls went on a trip from C. Find the number girls who did not go on the trip from A and C together is what percentage of the total students in A. (Number of boys > number of girls in each section).

- (a) 65%
- (b) 62%
- (c) 44%
- (d) 48%
- (e) 42%

Directions (46-50): The pie chart given below shows the percentage distribution of males in four different villages and the table shows the number of females is how many less than that of males in each village. Read the pie chart and table carefully to answer the following questions.

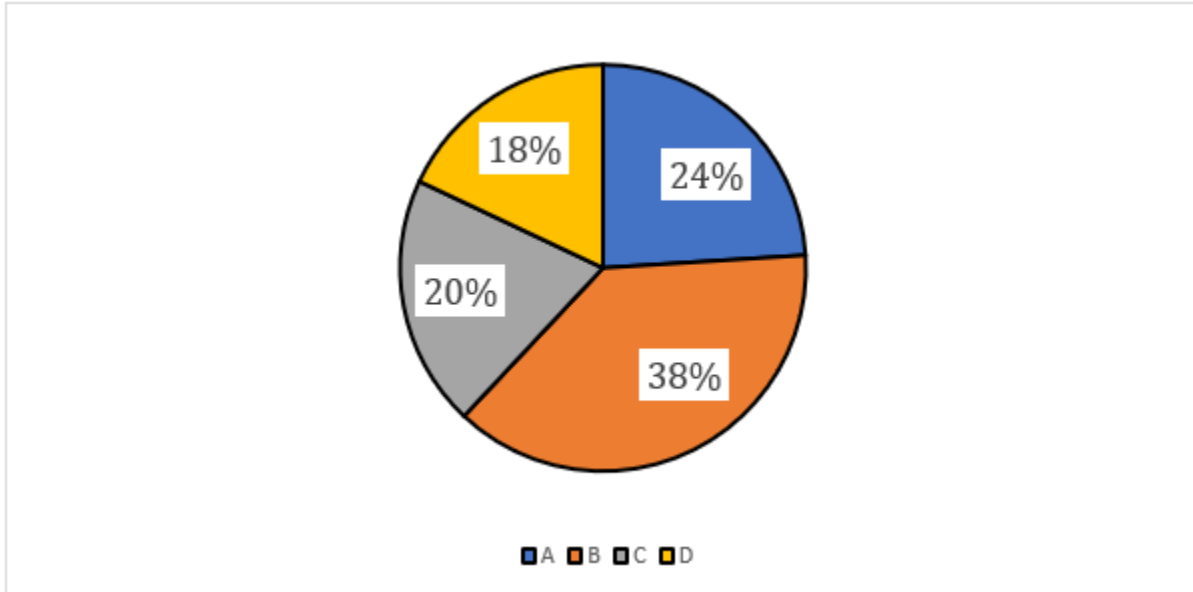

Village	Females less than males
A	180
B	210
C	250
D	160

Note: (i) Difference between the males in A and C village is 80.

(ii) Total people in the village = males + females.

Q46. Find the ratio of the number of males in village A and C together to the number of females in B and D together.

- (a) 88:75
- (b) 81:73
- (c) 83:77
- (d) 89:77
- (e) 89:71

Q47. Number of males in A is what percentage more or less than the males in the C.

- (a) 25%
- (b) 30%
- (c) 40%
- (d) 20%
- (e) 10%

Q48. If the data of females is distributed in the form of degree in the pie chart, then find the difference between corresponding angle formed by the number of females in village D and C.

- (a) 12°
- (b) 18°
- (c) 20°
- (d) 25°
- (e) 15°

Q49. Ratio of people who worked in urban area to the rural area from village A is 8: 5. Find the difference between the people who worked in rural area in A and the males in D

- (a) 60
- (b) 80
- (c) 40
- (d) 50
- (e) 70

Q50. Find the average number of people in all the villages.

- (a) 700
- (b) 800
- (c) 500
- (d) 400
- (e) 200

Directions (51-55): Read the following table carefully and answer the questions given below.

The table shows the total number of students who enrolled, percentage of students rejected and ratio of students who appeared to non-appeared students from five different states, J&K, MP, UP, HP and UK, for XYZ entrance exam.

States	Total students enrolled	Percentage of rejected students	Ratio of appeared to non-appeared students
J&K	50000	10%	5: 4
MP	60000	30%	5: 2
UP	48000	25%	3: 1
HP	32000	25%	2: 1
UK	20000	15%	10: 7

Q51. Total number of students who appeared in the exam from UK is how much more/less than the total number of students who non appeared in the exam from MP.

- (a) 5000
- (b) 4000
- (c) 8000
- (d) 6000
- (e) 2000

Q52. If from another state Goa, the number of students who appeared in the exam is 50% more than the number of students who enrolled in UK and total enrolled students are 25% less than the total enrolled students in UP, then find the number of students who didn't appear in then exam? (No application got rejected from Goa)

- (a) 6000
- (b) 8000
- (c) 5000
- (d) 4000
- (e) 7000

Q53. Find the ratio of number of students who appeared from MP for exam to total number of students whose application got rejected from J&K?

- (a) 9:5
- (b) 7:9
- (c) 6:1
- (d) 9:7
- (e) None of the above

Q54. Find the number of students who appeared from MP are what percent more/less than the total number of students who got rejected from HP?

- (a) 230%
- (b) $212\frac{1}{2}\%$
- (c) 220%
- (d) $133\frac{1}{3}\%$
- (e) 275%

Q55. Find the sum of total students who appeared in the exam from MP, UP & HP.

- (a) 40000
- (b) 84400
- (c) 62000
- (d) 51200
- (e) 73000

Directions (56-60): Study the bar chart given below and answer the following questions.

Bar chart shows total number of cars manufactured (in '000) by five different companies (A, B, C, D & E) in 2018 and percentage of sold cars out of total manufactured cars for each of these 5 companies.

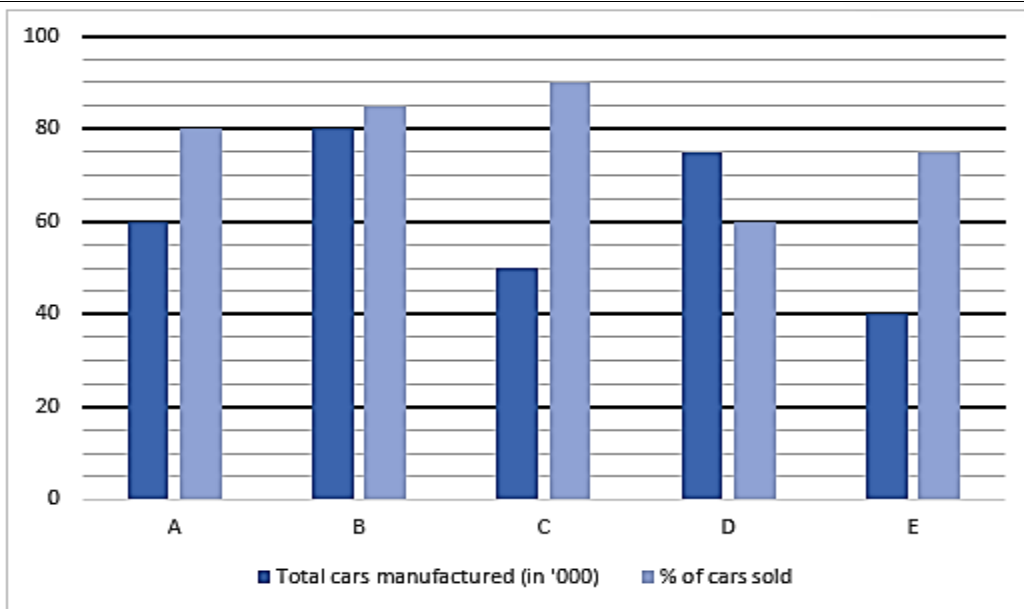

Q56. If total cars sold by F in 2018 is 25% more than total cars sold by A in 2018 and total unsold cars of F in 2018 is 20% of total cars manufactured by F in 2018, then find total cars manufactured by F in 2018 is how much more or less than total cars manufactured by B in 2018?

- (a) 8,000
- (b) 6,000
- (c) 5,000
- (d) 7,000
- (e) 4,000

Q57. Find out the average number of unsold cars of companies A, C and E together in 2018.

- (a) 9,000
- (b) 16,000
- (c) 15,000
- (d) 12,000
- (e) 10,000

Q58. If C manufactures only sedan cars and SUV cars and ratio of sedan cars and SUV cars manufactured by C in 2018 is 14:11 and sedan cars sold by C in 2018 are 25% more than SUV cars sold by C in 2018, then find unsold sedan cars of C in 2018 is what percent of total unsold cars of A in 2018?

- (a) 15%
- (b) 30%
- (c) 20%
- (d) 35%
- (e) 25%

Q59. Total cars sold by A and B together in 2018 are what percent more or less than the total cars sold by C & D together in 2018?

- (a) $17\frac{8}{9}\%$
- (b) $34\frac{8}{9}\%$
- (c) $23\frac{8}{9}\%$
- (d) $28\frac{8}{9}\%$
- (e) $26\frac{8}{9}\%$

Q60. If total cars manufactured by E in 2019 are 50% more than total cars manufactured by E in 2018 and total unsold cars of E in 2019 is 4,000 less than total unsold cars of E in 2018, then find cars sold by E in 2019 are how much more or less than cars sold by C in 2018?

- (a) 5,000
- (b) 9,000
- (c) 8,000
- (d) 10,000
- (e) 6,000

Directions (61-67): Read the following passage and answer the questions that follow. Some words in the passage have been highlighted to aid in answering the question.

The philosophy of education is a field of study that seeks to **understand** the nature, purpose, and methods of education. It involves examining the principles and values that guide educational practices, as well as the social, cultural, and historical contexts in which education occurs.

At its core, the philosophy of education is concerned with the question of what it means to be an educated person and how we can foster that development in others. This requires an understanding of the goals and objectives of education, such as the acquisition of knowledge, the development of critical thinking skills, and the cultivation of ethical and moral values.

Moreover, the philosophy of education recognizes that education is not a neutral or value-free **enterprise**. Rather, it is shaped by the cultural, social, and political contexts in which it occurs. Therefore, it is essential to consider the power dynamics that exist within educational institutions and to critically examine the assumptions and biases that underlie educational practices.

In practice, the philosophy of education is a _____ and ongoing conversation that involves educators, researchers, policymakers, and other stakeholders. It provides a framework for reflecting on the goals and values of education and for making decisions about how best to achieve those goals. Ultimately, the philosophy of education is an essential component of any effort to improve educational outcomes and to create a more just and equitable society.

Q61. What is the goal of the philosophy of education in promoting fairness and equality through educational practices and principles?

- (a) To establish proficient members of the community who can contribute effectively.
- (b) To emphasize the importance of personal accomplishment rather than collaborative advancement.
- (c) To create a more just and equitable society by advancing impartiality and parity.
- (d) To prioritize individual achievement over collaborative progress.
- (e) None of the above

Q62. In what capacity does the educator function in the philosophy of education?

- (a) As a facilitator of knowledge and learning processes.
- (b) As an enforcer of rules and discipline.
- (c) As a passive observer of students' progress.
- (d) As a provider of grades and evaluations.
- (e) As a promoter of standardized testing.

Q63. In what manner can the philosophy of education influence forthcoming times?

- (a) By shaping educational policies and practices to meet the evolving needs of society.
- (b) By discouraging critical thinking and creativity in learners, hindering their ability to adapt to future challenges.
- (c) By promoting standardized testing as the sole measure of educational success, neglecting other important aspects of learning.
- (d) By advocating for a one-size-fits-all approach to education, disregarding individual differences and diverse learning styles.
- (e) By prioritizing rote memorization over conceptual understanding and application of knowledge.

Q64. In what manner can the philosophy of education be defined?

- (a) A collection of fundamental beliefs and values directing the implementation of education
- (b) The spatial configuration of an educational space
- (c) The analysis of the past of educational practices
- (d) A particular approach to teaching
- (e) None of the above.

Q65. Which of the following words is the most similar in its definition as the highlighted word understand, the definition corresponding to its usage in the passage?

- (a) penetrate
- (b) misinterpret
- (c) comprehend
- (d) misconstrue
- (e) irresistible

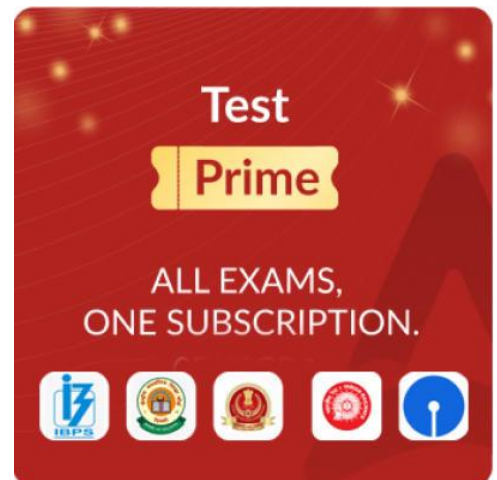

Q66. Which of the following words is the most opposite in its definition as the highlighted word enterprise, the definition corresponding to its usage in the passage?

- (a) gamble
- (b) company
- (c) firm
- (d) ambition
- (e) inertia

Q67. Which of the following fills the highlighted blank in the passage appropriately?

- (a) dynamic
- (b) frail
- (c) effete
- (d) impotent
- (e) feeble

Directions (68-72): Read the following passage and answer the given questions. Some words are highlighted aid in answering the questions.

Time is a fundamental concept that has been debated by philosophers, scientists, and artists for centuries. In its most basic form, time is defined as a measurement of duration, but it also has complex dimensions that relate to human perception and cultural influences. From the perspective of physics, time is a relative measure of the motion of objects, and it is defined by the interval between two events. However, this objective definition of time is often at odds with the subjective experience of time by human beings.

One of the most significant challenges of understanding time is the perception of time by humans, which can vary based on several factors, including age, mood, and cultural background. For example, a person who is bored may feel that time is passing more slowly than someone who is engaged in an activity they enjoy. Similarly, the perception of time varies across different cultures, with some cultures having a more relaxed attitude towards time, while others place a greater **emphasis** on punctuality.

In addition to these subjective dimensions, time is also an essential aspect of human culture. The measurement of time has allowed humans to organize their lives and create a sense of order in the world. Time is used to regulate social behaviour, and it is also a critical factor in economic and political systems. The cultural significance of time is **evident** in the vast number of idioms and expressions that refer to time in different languages, such as “time is money” or “time flies when you're having fun.”

Overall, time is a complex concept that has both objective and subjective dimensions. The scientific definition of time is based on physical laws and objective measurements, but it is also influenced by cultural and personal factors that can affect human perception of time.

Q68. From the perspective of physics, how is time defined?

- (a) Time is a subjective measurement of duration.
- (b) Time is an absolute measure of duration.
- (c) Time is a relative measure of the motion of objects.
- (d) Time is a constant and unchanging dimension.
- (e) Time is a function of human perception.

Q69. Which of the following factors can affect human perception of time?

- (a) Cultural background and political systems
- (b) Mood and level of engagement in an activity
- (c) Degree of proficiency in scientific study
- (d) Gender and personality traits
- (e) All of these

Q70. What is the significance of the measurement of time in human culture?

- (a) It has allowed humans to live lives in a more organised manner.
- (b) It is a measured very precisely using specified tools and algorithms.
- (c) It is irrelevant to social behaviour and administration.
- (d) It has no impact on economic and political systems.
- (e) It is limited to scientific research and experimentation.

Q71. Which of the following can signify the cultural significance of time according to the passage?

- (a) It has no impact on social behaviour or organization.
- (b) It is limited to scientific research and experimentation.
- (c) Its importance has inspired many expressions in many languages.
- (d) It is a function of subjective human perception.
- (e) It is used primarily in artistic expression.

Q72. Which of the following is the most appropriate antonym for the word “emphasis” as is highlighted in the passage?

- (a) enhancement
- (b) disregard
- (c) endeavour
- (d) sequence
- (e) constriction

Directions (73-77): In the following questions two columns are given, each containing three phrases/sentences. Choose the option that will connect the phrases to form meaningful and correct sentences.

Q73. COLUMN (I)

- (A) The government has announced
- (B) As per recent reports, the economy
- (C) Experts are of the opinion that the

COLUMN (II)

- (D) government needs to implement immediate measures
- (E) is showing signs of a fast recovery
- (F) great aspirations in outer space

- (a) Only B-E and C-D
- (b) Only A-D and C-F
- (c) Only B-D and C-E
- (d) Only A-F and C-D
- (e) None of these

Q74. COLUMN (I)

- (A)** The police have recently launched a massive
- (B)** The minister of agriculture has announced
- (C)** The educational institutions are facing

COLUMN (II)

- (D)** campaign to curb and prevent cybercrime.
- (E)** a new policy to determine minimum support price.
- (F)** protesting against the fees hikes in recent years.

- (a) Only A-F and B-E
- (b) Only B-E and C-F
- (c) Only A-F and C-D
- (d) Only B-E and A-D
- (e) None of these

Q75. COLUMN (I)

- (A)** The majestic mountain range stretched as far
- (B)** In the aftermath of the pandemic
- (C)** Despite several rounds of negotiations

COLUMN (II)

- (D)** the two countries failed to reach a resolution on the trade dispute
- (E)** pang of sadness as she said goodbye to her friend.
- (F)** so company has decided to relocate its manufacturing facilities.

- (a) Only A-D
- (b) Only C-D
- (c) Only A-F and B-D
- (d) Only B-E and A-D
- (e) None of these

Q76. COLUMN (I)

- (A)** Although he had no prior experience in the field
- (B)** The athlete trained tirelessly to prepare for the
- (C)** The children giggled as they played in the

COLUMN (II)

- (D)** the company's stock price continued to plummet
- (E)** many investors are bullish on the prospects of the tech sector
- (F)** he managed to turn the company around in just a year

- (a) Only A-D
- (b) Only A-D and C-E
- (c) Only A-F
- (d) Only B-D and C-F
- (e) None of these

Q77. COLUMN (I)

- (A)** Despite the mountains in the distance looked majestic
- (B)** I have to wake up early tomorrow for
- (C)** The policy makers' decision to hike taxes

COLUMN (II)

- (D)** many consumers continue to remain loyal to the brand
- (E)** the company has decided to launch a new product line
- (F)** has drawn criticism from several quarters.

- (a) Only B-E
- (b) Only B-E and C-F
- (c) Only A-F and B-D
- (d) Only C-F
- (e) None of these

Directions (78-82): In each of the questions given below four words are given in bold. These five words may or may not be in their correct position. The sentence is then followed by options with the correct combination of words that should interchange with each other in order to make the sentence grammatically and contextually correct. Find the correct combination of the words that replace each other.

Q78. The idea of mindfulness has become increasingly **popular (A)** among people **seeking (B)** to improve **(C)** stress and **reduce (D)** their well-being.

- (a) B-A
- (b) A-D and B-C
- (c) D-C
- (d) B-C
- (e) No interchange required

Q79. The team's **opponents (A)** in the championship were ultimately **unsuccessful (B)** as they lost the **final (C)** game to their **efforts (D)**.

- (a) B-C
- (b) D-C
- (c) A-D and B-C
- (d) A-D
- (e) No interchange required

Q80. She had to **decided (A)** between **helping (B)** to the party or **going (C)** out her parents, but she ultimately **choose (D)** on the former.

- (a) A-C
- (b) A-D and B-C
- (c) B-C
- (d) A-D
- (e) No interchange required

Q81. Kerala **easing (A)** some of the **relaxations(B)** it had **granted(C)** earlier today, in line with the staggered **revoked (D)** of lockdown,

- (a) (A) - (B)
- (b) (B) - (C)
- (c) (A) - (D)
- (d) (A) - (D) and (B) and (C)
- (e) No interchange required

Q82. Vijay Mallya had **against (A)** to the High Court **appealed (B)** his extradition to India at a **this (C)** in February **hearing (D)** year.

- (a) (A) - (D)
- (b) (B) - (C)
- (c) (A) - (B)
- (d) (C) - (D) and (B) and (A)
- (e) No interchange required

Directions (83-85): A word has been given in each question and used in the sentences given below. Identify the statements where the word has been used in a contextually and grammatically correct manner. If the word has been used incorrectly in all the statements, mark "None of these", as your answer.

Q83. Consistent

- (i) The **consistent** models of economic growth have led to unsustainable patterns of natural resource exploitation.
 - (ii) She's one of the team's most **consistent** players.
 - (iii) There is **consistent** evidence of climate change deriving from socially constructed vulnerabilities.
- (a) Only (i)
 - (b) Only (ii)
 - (c) Both (ii) and (i)
 - (d) Both (ii) and (iii)
 - (e) None of these

Q84. Vulnerable

- (i) The Mahanadi delta is among the most **vulnerable** deltas in the world.
 - (ii) In the study, villagers reported issues of **vulnerable** agricultural production.
 - (iii) Collaboration between groups that is **vulnerable** to both parties should be promoted.
- (a) Only (i)
 - (b) Only (ii)
 - (c) Both (ii) and (i)
 - (d) Both (ii) and (iii)
 - (e) None of these

Q85. Prominent

- (i) Water availability and quality have been one of the most **prominent** issues.
 - (ii) Development plans have increasingly diverted water to industrial areas at the **prominent** of rural communities.
 - (iii) The gender gap in education is less **prominent** in the delta region than in other areas of Odisha.
- (a) Only (i)
 - (b) Only (ii)
 - (c) Both (iii) and (i)
 - (d) Both (ii) and (iii)
 - (e) None of these

Directions (86-87): In each question three sentences are given corresponding to a single idiom/phrasal verb. Choose the sentence(s) that have the correct usage of the given idiom.

Q86. Run out of

- (A) We need to go to the store because we've **run out of** milk.
 - (B) During the power outage, we **ran out of** candles and had to use a flashlight instead
 - (C) The marathon runner **ran out of** energy and couldn't finish the race.
- (a) Only (A)
 - (b) Only (B)
 - (c) Only (C)
 - (d) only (A) and (C)
 - (e) All of the above

Q87. Come up with

- (A) Can you **come up with** a better solution?
 - (B) We **came up with** the beach yesterday, and it was so hot.
 - (C) She **came up with** a brilliant idea for the project.
- (a) Only (A)
 - (b) Only (A) and (C)
 - (c) Only (C)
 - (d) Only (C) and (B)
 - (e) Only (B)

Directions (88-92): Read each sentence to find out whether there is any grammatical or idiomatic error in it. The error, if any, will be in one part of the sentence. The corresponding letter of that part is the answer. If the given sentence is correct as it is, then choose option 'No error' as your answer response. (Ignore errors of punctuation, if any).

Q88. The sound of (A)/ the alarm clock (B)/ ringing incessant (C)/ was driving her crazy. (D)

- (a) A
- (b) B
- (c) C
- (d) D
- (e) No error

Q89. A militia is a group (A)/ of non-professional soldiers (B)/ who have typically composed (C)/ of citizens. (D)

- (a) A
- (b) B
- (c) C
- (d) D
- (e) No error

Q90. The cultural and social (A)/ norms of a society (B)/ can become deeply (C)/ entrench over time. (D)

- (a) A
- (b) B
- (c) C
- (d) D
- (e) No error

Q91. The military organized (A)/ a large-scale evacuation (B)/ of the civilians trapped (C)/ in the conflict zone. (D)

- (a) A
- (b) B
- (c) C
- (d) D
- (e) No error

Q92. Detention refers to (A)/ the act of hold (B)/ someone in custody as (C)/ a form of punishment. (D)

- (a) A
- (b) B
- (c) C
- (d) D
- (e) No error

Directions (93-95): In the questions given below two sentences are given which are grammatically correct and meaningful. Connect them by the word given below the statements in the best possible way without changing the intended meaning. Choose your answer accordingly from the options which form a correct, coherent sentence.

Q93. (I) They had conflicting opinions and viewpoints but
(II) found common ground and reached a compromise

- (a) In reality
- (b) Briefly
- (c) Additionally
- (d) Along with
- (e) Nevertheless

Q94. (I) They started off as strangers, but through shared experiences and conversations they
(II) became close friends

- (a) indeed
- (b) in spite of
- (c) eventually
- (d) and
- (e) whereas

Q95. (I) The play was highly praised for the inspired performance of the cast
(II) the lead actor's compelling portrayal

- (a) notably
- (b) furthermore
- (c) apart from
- (d) even so
- (e) therefore

Directions (96-97): Each question below has one blank, which is indicating that something has been omitted. Find out which option can be used to fill up the blank in the sentence to make it grammatically as well as contextually correct.

Q96. The new employee's _____ was evident from the way he took on every task with enthusiasm and eagerness to learn.

- (a) reluctance
- (b) indifference
- (c) diligence
- (d) scepticism
- (e) frivolity

Q97. The novel's intricate plot and richly drawn characters made it a _____ read for lovers of literary fiction.

- (a) tedious
- (b) banal
- (c) insipid
- (d) trite
- (e) captivating

Directions (98-100): In the following question, sentences are given with a part in bold. The given phrase in the bold may or may not contain an error. The options following can replace the incorrect phrase. The correct phrase that is to be replaced will be your answer. If the sentences are correct then select option 'No replacement required' as your answer.

Q98. The team's success in completing the project ahead of schedule was due to their **efficient time managed skills**.

- (a) efficient time manage skills
- (b) efficiency time management skills
- (c) efficient time management skills
- (d) efficient timed management skills
- (e) No replacement required

Q99. The board's decision to increase the company's advertising budget was motivated **of a desire to** attract new customers.

- (a) with a desire to
- (b) by a desire to
- (c) for a desire to
- (d) to a desire to
- (e) No replacement required

Q100. The manager's failure **to communicate clearly** led to misunderstandings among team members.

- (a) to communicate clarity
- (b) to communicate in clarity
- (c) to communicate with clearness
- (d) to communicate in clearness
- (e) No replacement required

Directions (101-105): What approximate value will come in the place of question (?) marks:

Q101. $31.93\% \text{ of } 750.03 + ?^2 = 48.03\% \text{ of } 1699.98$

- (a) 24
- (b) 22
- (c) 18
- (d) 26
- (e) 28

Q102. $\frac{1151.98}{?} + 24.03\% \text{ of } 450.01 = 12.01 \times 12.98$

- (a) 48
- (b) 12
- (c) 24
- (d) 18
- (e) 6

Q103. $?^3 \times (80.01\% \text{ of } 40.01 + 2^3) = 80.01\% \text{ of } 10800.03$

- (a) 6
- (b) 2
- (c) 4
- (d) 8
- (e) 3

Q104. $1268.03 + 1727.98 - ? = (10.01)^3$

- (a) 1856
- (b) 1906
- (c) 1896
- (d) 1916
- (e) 1996

Q105. $? \times (56.01\% \text{ of } 549.98 + 112.01) = 70.01\% \text{ of } 2999.98$

- (a) 7
- (b) 5
- (c) 3
- (d) 8
- (e) 10

Q106. Shivam lent Rs.X at 20% p.a. at SI for 2 years to Vikas and Vikas then lent 80% of money borrowed from Shivam to Harish at 25% p.a. at SI for 2 years and invested rest borrowed amount in a scheme offering 30% p.a. at SI for 2 years. If at the end of the 2 years Vikas repaid his debt and earned Rs.6,000 in the whole transaction, then find X.

- (a) 30,000
- (b) 45,000
- (c) 50,000
- (d) 35,000
- (e) 25,000

Q107. Vessel-P contains 100l mixture of oil and water in the ratio 3:2 respectively and vessel-Q contains T liters mixture of oil and water in the ratio 7:5 respectively. Complete mixture of both vessels is mixed in another vessel-R and ratio of oil and water in vessel-R becomes 33:23 respectively. Find T?

- (a) 180
- (b) 150
- (c) 120
- (d) 200
- (e) 160

Q108. Time taken by pipes A, B and C together to fill a tank is 45 minutes and time taken by pipes B and C together to fill the same tank is 75 minutes. If pipe B is 100% more efficient than pipe C, then find time taken by pipe A & B together to fill the same tank.

- (a) 56.25 minutes
- (b) 50.25 minutes
- (c) 46.25 minutes
- (d) 54.25 minutes
- (e) None of the above.

Q109. Ratio of cost price of a pen to that of a pencil is 3:4 and shopkeeper marked each of pen and pencil 20% above their respective cost prices. If shopkeeper allowed 10% discount on each of pen & pencil and earned a total of Rs. 2.8 on selling a pen & a pencil, then find the cost price of a pen.

- (a) Rs.25
- (b) Rs.15
- (c) Rs.35
- (d) Rs.45
- (e) Rs.55

Q110. Age of A is 16 years more than that of C and ratio between ages of B & C, 5 years hence is 7:5 respectively. If present age of B is 75% of age of A 4 years hence, then find present age of A is what percent of the sum of present ages of B & C together?

- (a) 54%
- (b) 60%
- (c) 78%
- (d) 72%
- (e) 66%

Directions (111-115): In the following questions, two equations (I) and (II) are given. You have to solve both the equations and mark the answer accordingly.

Q111.

I. $18x^2 + 33x + 14 = 0$

II. $8y^2 + 22y + 15 = 0$

- (a) $x < y$
- (b) $x > y$
- (c) $x \leq y$
- (d) $x \geq y$
- (e) $x = y$ or no relation.

Q112.

I. $x^2 - 12x + 32 = 0$

II. $y^2 - 15y + 54 = 0$

- (a) $x < y$
- (b) $x > y$
- (c) $x \leq y$
- (d) $x \geq y$
- (e) $x = y$ or no relation.

Q113.

I. $7x^2 + 27x + 18 = 0$

II. $2y^2 + 13y + 21 = 0$

- (a) $x < y$
- (b) $x > y$
- (c) $x \leq y$
- (d) $x \geq y$
- (e) $x = y$ or no relation.

Q114.

I. $6x - 8y = 7$

II. $4x + 3y = 38$

- (a) $x < y$
- (b) $x > y$
- (c) $x \leq y$
- (d) $x \geq y$
- (e) $x = y$ or no relation.

Q115.

I. $40x^2 - 81x + 35 = 0$

II. $2y^2 - 7y + 3 = 0$

- (a) $x < y$
- (b) $x > y$
- (c) $x \leq y$
- (d) $x \geq y$
- (e) $x = y$ or no relation.

Q116. A, B and C started a business by investing in the ratio of 3 : 4 : 5. After 3 months, A withdrew an amount which is equal to $8\frac{1}{3}\%$ of total amount invested by B and C together. If A got Rs. 702 at end of year, then find the difference between profit share of B and C?

- (a) Rs. 280
- (b) None of these
- (c) Rs. 320
- (d) Rs. 240
- (e) Rs. 300

Q117. A spherical ball is melted to form 63 identical cylindrical vessels. If radius of each cylindrical vessel is $33\frac{1}{3}\%$ of radius of spherical ball and height of each cylindrical vessel is 3cm less than radius of each cylindrical vessel, then find radius of spherical ball.

- (a) 21cm
- (b) 14cm
- (c) 35cm
- (d) 49cm
- (e) 42cm

Q118. Vikash and Mohit started from point A towards point Q. Distance between A and Q is 9 km. If Mohit starts after 4 min., then he will meet Vikash 1 km away from point Q at a time when Vikash is returning towards point A after reaching point Q and Vikash can cover 1 km in 6 min. find speed of Mohit in km/min.

- (a) $\frac{1}{7}$
- (b) $\frac{1}{8}$
- (c) $\frac{1}{9}$
- (d) $\frac{1}{6}$
- (e) $\frac{1}{12}$

Q119. A Boat is moving in downstream and speed of Boat in still water is 5 times speed of current. After 16 km due to technical problem speed of boat (in still water) reduced by 20 % and it cover 40 km distance with this speed. If average speed of whole journey is $7/20$ km/min, then find speed of current.

- (a) $4\frac{1}{8}$ km/hr
- (b) $2\frac{7}{10}$ km/hr
- (c) 4 km/hr
- (d) 5 km/hr
- (e) $4\frac{3}{8}$ km/hr

Q120. Train 'A' can cross a pole and 200 meters long platform in 16 seconds & 24 seconds respectively. Find time taken by train 'A' to cross another train 'B', which length is 480 meters and running at the speed of 108 km/hr. in opposite direction.

- (a) 25 seconds
- (b) 24 seconds
- (c) 18 seconds
- (d) 20 seconds
- (e) 16 seconds

Directions (121-125): Given below in each question there are two statements (I) and (II). You must determine; which statement is enough to give the answer of question. Also, there are five alternatives given, you have to choose one alternative as your answer of the questions:

Q121. What will be area of rectangle.

I. Sum of diameter of circle and two times of length of rectangle is 76 cm.

II. sum of perimeter of rectangle and radius of circle is 94 cm.

- (a) only statement I
- (b) Only statement II
- (c) Both I and II together
- (d) Either I or II alone
- (e) Both statements together are not sufficient

Q122. What is age of A after two years.

I. Average of present age of B and C is 48 years and present age of B is 50% more than present age of A.

II. C is 8 years elder than D and ratio of present age of D to A is 1 : 2.

- (a) Both I and II together
- (b) Only statement II
- (c) only statement I
- (d) Either I or II alone
- (e) Both statements together are not sufficient

Q123. If speed of train A is 72 km/hr, then find out the length of train A

I. Train A crosses another train B moving in opposite direction in 12 sec and the speed of train B is 50% more than the speed of train A.

II. Ratio of length of train B to train A is 1 : 2.

- (a) Either I or II alone
- (b) Only statement I
- (c) Only statement II
- (d) Both I and II together are not sufficient
- (e) Both I and II together

Q124. A basket contains total 12 units of 3 types of fruits in which there are five apples and rest are oranges and pears. What is difference between oranges & pears.

I. If one fruit taken out from basket randomly then probability of it being either orange or pear is $\frac{7}{12}$

II. If two fruits taken out from basket randomly then probability of both being either oranges or pears is $\frac{1}{6}$.

- (a) Only statement II is sufficient
- (b) Either statement I or Statement II alone is sufficient
- (c) Statement I and II both together is sufficient
- (d) Only statement I is sufficient
- (e) Neither statement I nor statement II is sufficient

Q125. What is his percentage profit in the whole transaction?

I. Veer purchased 20 dozen pens at Rs. 40 per dozen.

II. Veer sold 8 dozen pens at 10% profit and 12 dozen pens at 20% profit.

- (a) Only statement II is sufficient
- (b) Either statement I or Statement II alone is sufficient
- (c) Statement I and II both together is sufficient
- (d) Only statement I is sufficient
- (e) Neither statement I nor statement II is sufficient

Directions (126-130): Study the passage given below and answer the following questions.

A store sold 5 different products (P, Q, R, S & T) in 2018 & 2019. Units of P sold in 2019 are 90% of units of P sold in 2018. Ratio of units of P to Q sold in 2018 is 2:1. Units of Q & S sold in 2018 is same. Units of R sold in 2018 are 40% more than units of S sold in 2018. Units of T sold in 2018 are 2,000 less than units of R sold in 2018. Ratio of units of S sold in 2018 to units of Q sold in 2019 is 5:6. Units of P & R sold in 2019 is same.

Units of Q sold in 2019 are 60% of units of S sold in 2019. Units of R sold in 2018 is equal to units of T sold in 2019. Average of units of T sold in 2018 & 2019 is equal to units of Q sold in 2018.

Q126. Units sold of R & S together in 2018 are what percent of units sold of Q in 2019?

- (a) 160%
- (b) 200%
- (c) 240%
- (d) 150%
- (e) 180%

Q127. Find average number of units sold of Q, R & T in 2018.

- (a) 2,500 units
- (b) 2,000 units
- (c) 2,400 units
- (d) 2,700 units
- (e) 3,000 units

Q128. Find ratio of units sold of S & T together in 2018 to units sold of P & R together in 2019.

- (a) 2:3
- (b) 7:11
- (c) 5:8
- (d) 5:6
- (e) 4:9

Q129. Units sold of all these 5 products together in 2019 are what percent more or less than units sold of all these 5 products together in 2018?

- (a) $26\frac{2}{3}\%$
- (b) $46\frac{2}{3}\%$
- (c) $16\frac{2}{3}\%$
- (d) $36\frac{2}{3}\%$
- (e) None of the above.

Q130. If per unit selling price of P in both year (2018 & 2019) is Rs.32 and per unit cost price of P in both year (2018 & 2019) is Rs.26, then find total profit earned by the store by selling P in 2018 & 2019 together. (Consider store sold all the units of P in both these years)

- (a) Rs.45,000
- (b) Rs.54,000
- (c) Rs.64,000
- (d) Rs.57,000
- (e) Rs.69,000

Directions (131-135): Find the wrong number in the following number series.

Q131. 2030, 2050, 2000, 2100, 1900, 2300, 1500

- (a) 1500
- (b) 2030
- (c) 2050
- (d) 2100
- (e) 1900

Q132. 10, 6, 6, 9, 18, 45, 135

- (a) 9
- (b) 18
- (c) 135
- (d) 10
- (e) 45

Q133. 337, 318, 301, 278, 249, 218, 181

- (a) 318
- (b) 278
- (c) 301
- (d) 249
- (e) 218

Q134. 75, 100, 200, 425, 820, 1450, 2350

- (a) 2350
- (b) 425
- (c) 200
- (d) 820
- (e) 1450

Q135. 81, 100, 130, 171, 223, 285, 360

- (a) 81
- (b) 285
- (c) 360
- (d) 171
- (e) 100

Directions (136-140): Read the given information carefully and answer the following questions.

Total population of village A, B and C is 50000, 16000 and 43000 respectively. In each village, there are 3 categories of people i.e male, female and transgender. The ratio of male, female and transgender in village A is 16 : 7 : 2 respectively. The number of male and female is equal in village B whereas the ratio of female to transgender in village B is 7:2. In village C, the ratio of female to transgender is 14:11 and ratio of male to female in village C is 9 : 7.

Q136. What is the total number of females in village A and B together?

- (a) 21,000
- (b) 16,000
- (c) 15,000
- (d) 20,000
- (e) 19,000

Q137. What is the ratio of females in village A to that of in village C?

- (a) 3 : 2
- (b) 8 : 5
- (c) 7 : 4
- (d) 1 : 1
- (e) 2 : 7

Q138. What is the average of transgenders of village B and C?

- (a) 5500
- (b) 6000
- (c) 6500
- (d) 7000
- (e) 7500

Q139. Transgenders of village B are what percent of females of village C?

- (a) 20%
- (b) $16\frac{2}{3}\%$
- (c) $11\frac{1}{9}\%$
- (d) $14\frac{2}{7}\%$
- (e) $33\frac{1}{3}\%$

Q140. Females of village B are what percent of females of village A?

- (a) 40%
- (b) 25%
- (c) 50%
- (d) 60%
- (e) 45%

Solutions

S1. Ans.(b)

Sol. T is sitting at the fifth chair from the left end. Three persons are sitting between T and Z. Neither Z nor S are sitting at the end. Here we get three possibilities.

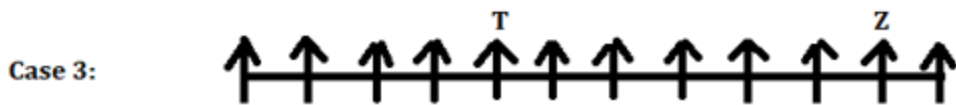
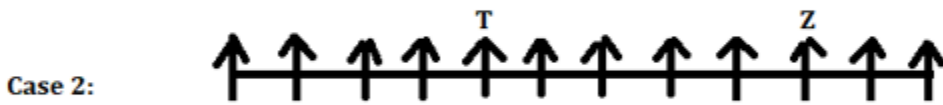
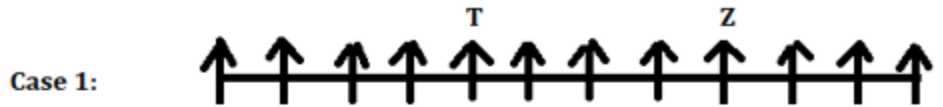

V is sitting at an even number chair. R is sitting at third chair to the left of V but none of them is sitting at the end. Only two vacant chairs are placed between R and S. Both S and U are sitting adjacent seat to neither Z nor V. One person is sitting between V and X who is sitting to the right of S. Here case 1 gets cancelled and one more case arise in case 3a.

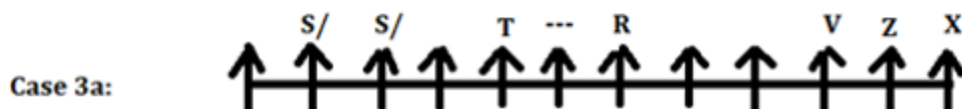
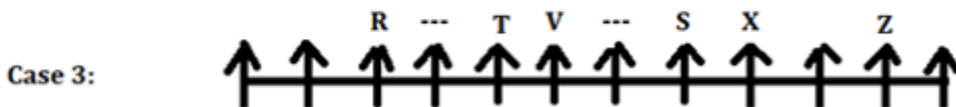
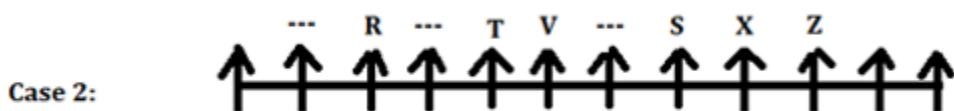
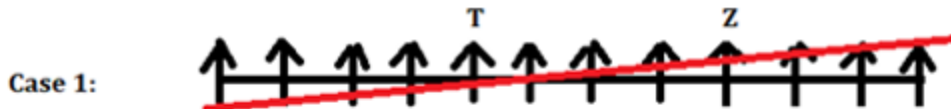

Two persons are sitting between U and V. U is not sitting adjacent to the vacant chair. Here case 2 and case 3a gets cancelled.

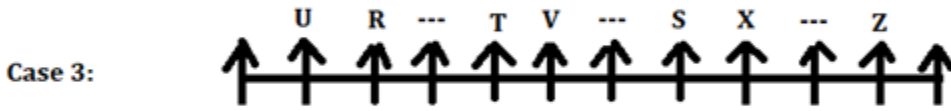
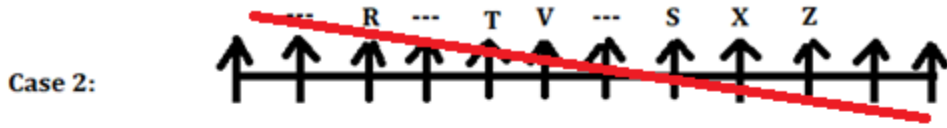

Y and Z are not sitting together. So, Y sits immediate left of U.

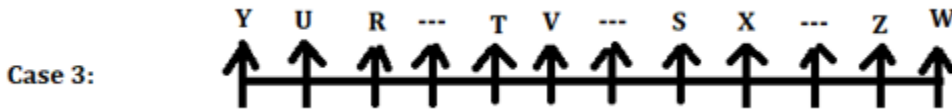

Final arrangement:

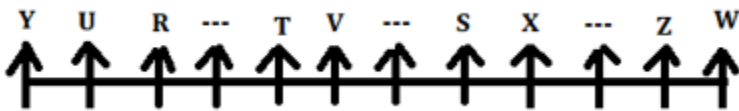

Four persons are sitting between R and Z.

S2. Ans.(c)

Sol. T is sitting at the fifth chair from the left end. Three persons are sitting between T and Z. Neither Z nor S are sitting at the end. Here we get three possibilities.

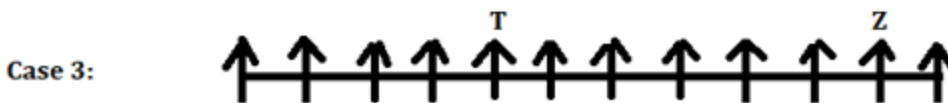
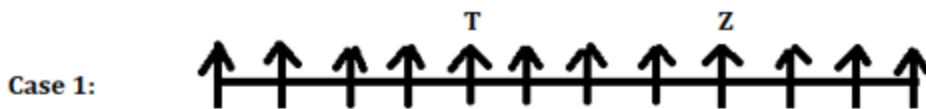

V is sitting at an even number chair. R is sitting at third chair to the left of V but none of them is sitting at the end. Only two vacant chairs are placed between R and S. Both S and U are sitting adjacent seat to neither Z nor V. One person is sitting between V and X who is sitting to the right of S. Here case 1 gets cancelled and one more case arise in case 3a.

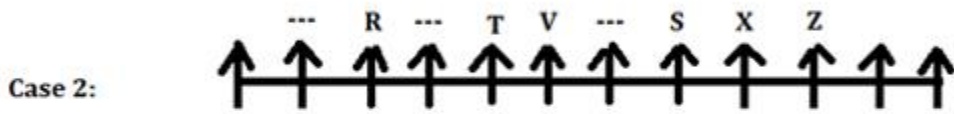
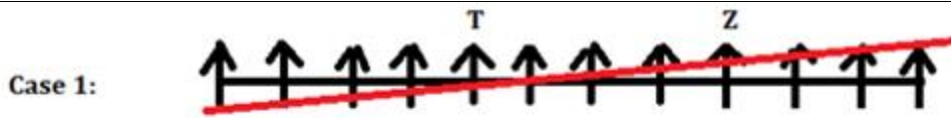

Two persons are sitting between U and V. U is not sitting adjacent to the vacant chair. Here case 2 and case 3a gets cancelled.

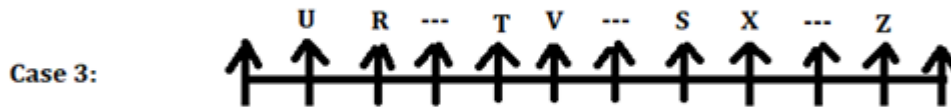
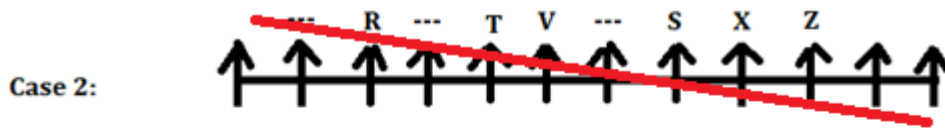

Y and Z are not sitting together. So, Y sits immediate left of U.

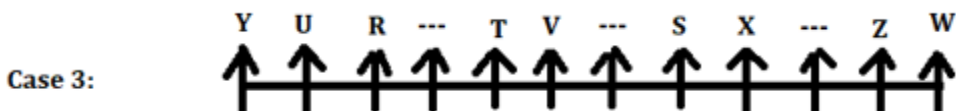

Final arrangement:

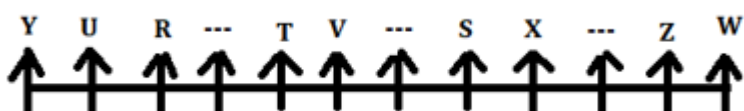

Statement in option (c) is not true.



S3. Ans.(c)

Sol. T is sitting at the fifth chair from the left end. Three persons are sitting between T and Z. Neither Z nor S are sitting at the end. Here we get three possibilities.

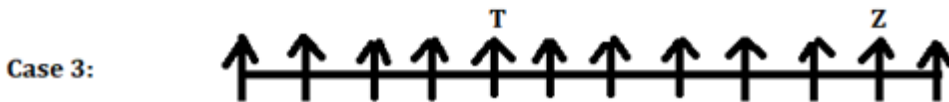
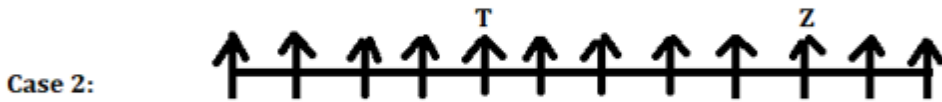
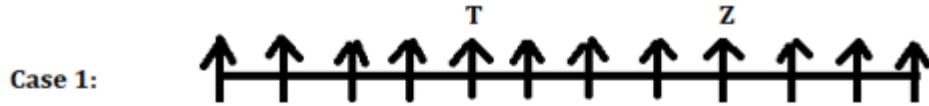

V is sitting at an even number chair. R is sitting at third chair to the left of V but none of them is sitting at the end. Only two vacant chairs are placed between R and S. Both S and U are sitting adjacent seat to neither Z nor V. One person is sitting between V and X who is sitting to the right of S. Here case 1 gets cancelled and one more case arise in case 3a.

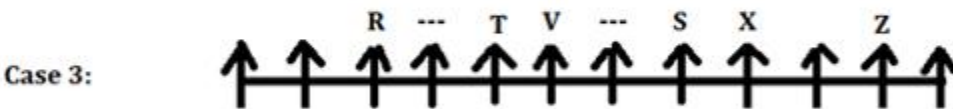
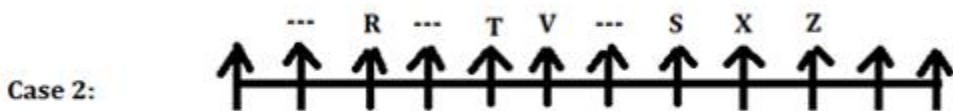
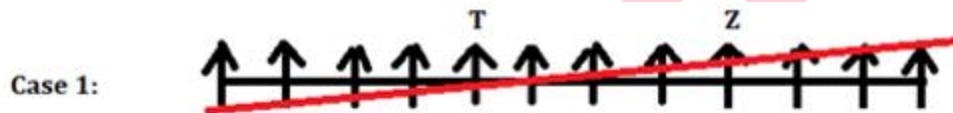

Two persons are sitting between U and V. U is not sitting adjacent to the vacant chair. Here case 2 and case 3a gets cancelled.

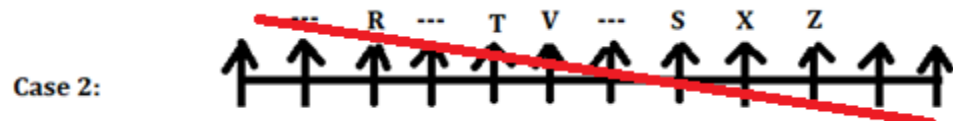

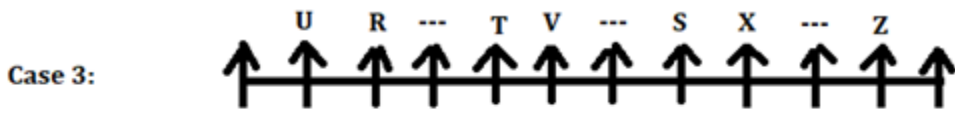

Y and Z are not sitting together. So, Y sits immediate left of U.

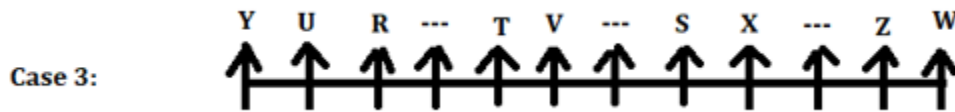

Final arrangement:

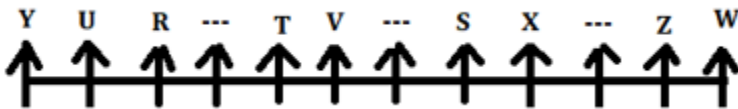

V sits immediate right of T.

S4. Ans.(d)

Sol. T is sitting at the fifth chair from the left end. Three persons are sitting between T and Z. Neither Z nor S are sitting at the end. Here we get three possibilities.

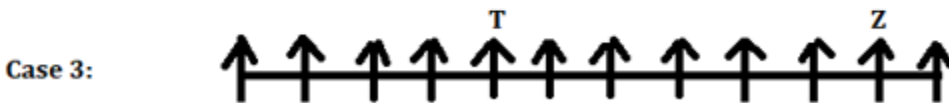
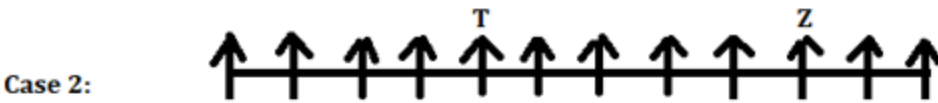
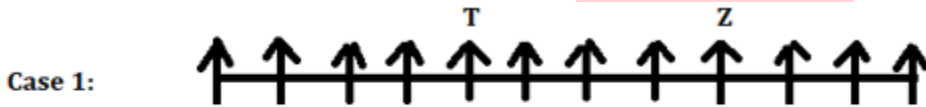

V is sitting at an even number chair. R is sitting at third chair to the left of V but none of them is sitting at the end. Only two vacant chairs are placed between R and S. Both S and U are sitting adjacent seat to neither Z nor V. One person is sitting between V and X who is sitting to the right of S. Here case 1 gets cancelled and one more case arise in case 3a.

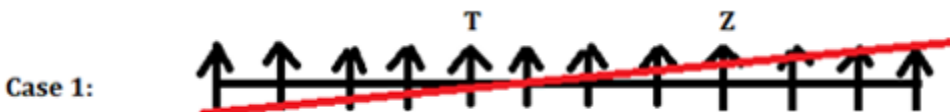

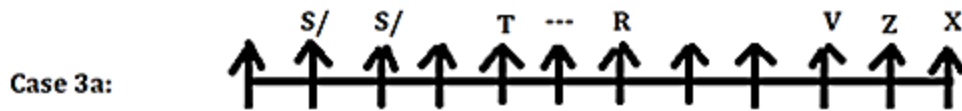
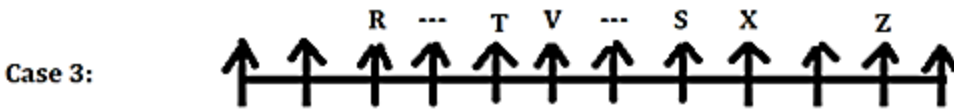
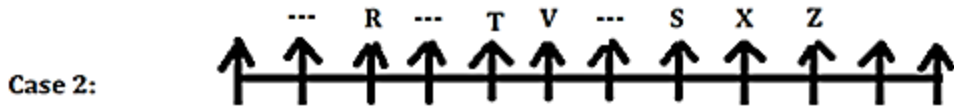

Two persons are sitting between U and V. U is not sitting adjacent to the vacant chair. Here case 2 and case 3a gets cancelled.

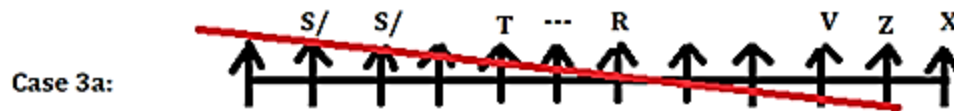
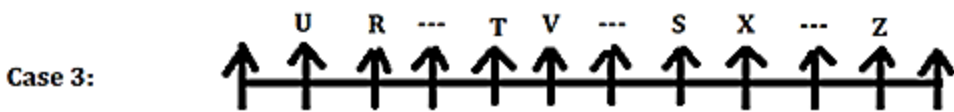
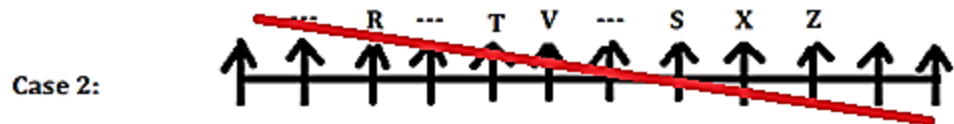

Y and Z are not sitting together. So, Y sits immediate left of U.

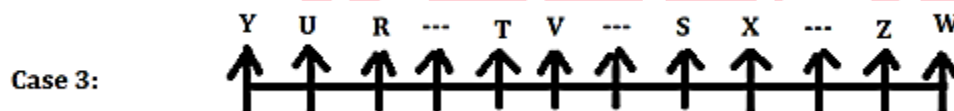

Final arrangement:

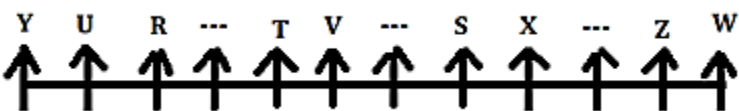

The position of X is fourth to the right of T.

S5. Ans.(a)

Sol. T is sitting at the fifth chair from the left end. Three persons are sitting between T and Z. Neither Z nor S are sitting at the end. Here we get three possibilities.

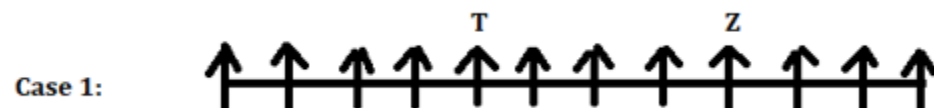

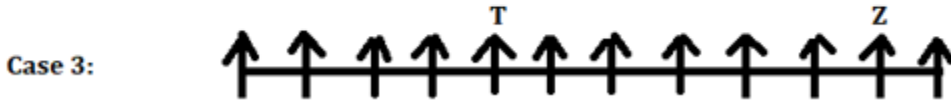
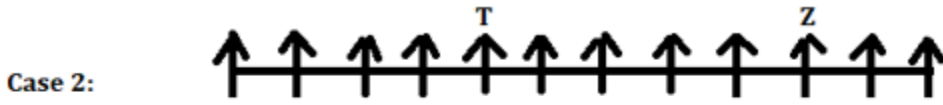

V is sitting at an even number chair. R is sitting at third chair to the left of V but none of them is sitting at the end. Only two vacant chairs are placed between R and S. Both S and U are sitting adjacent seat to neither Z nor V. One person is sitting between V and X who is sitting to the right of S. Here case 1 gets cancelled and one more case arise in case 3a.

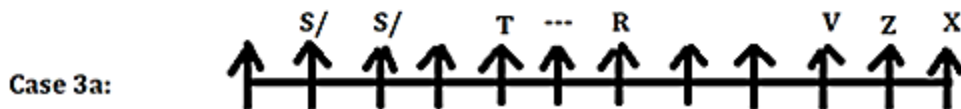
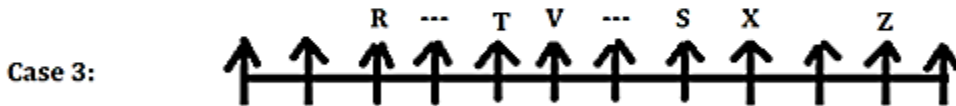
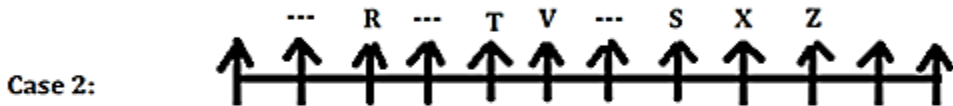
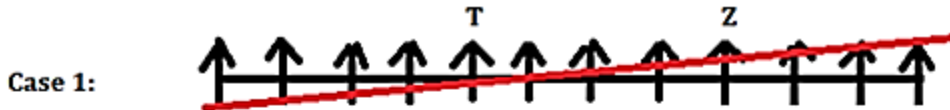

Two persons are sitting between U and V. U is not sitting adjacent to the vacant chair. Here case 2 and case 3a gets cancelled.

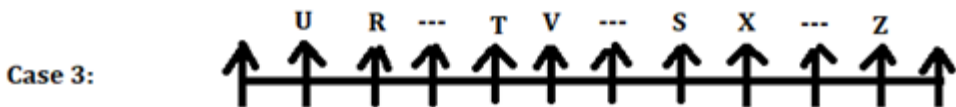
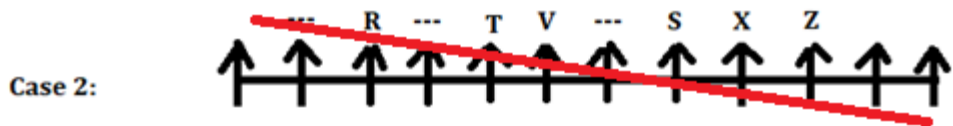

Y and Z are not sitting together. So, Y sits immediate left of U.

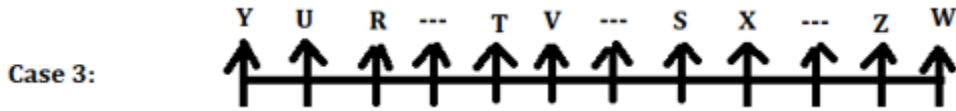

Final arrangement:

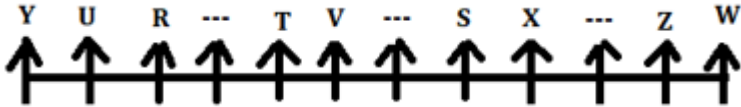

Only option (a) is true.

S6. Ans.(c)

Sol. Final arrangement:

Floors	Flat P	Flat Q
	4	A, Guitar
3	H, Harp	E, Violin
2	F, Cello	B, Drum
1	D, Flute	G, Piano

Clues: The one who likes Guitar lives two floors above the one who likes Drum. The one who likes drum lives on an even numbered floor.

Inference: We have four possible cases:

Floors	Case 1		Case 2		Case 3		Case 4	
	Flat P	Flat Q	Flat P	Flat Q	Flat P	Flat Q	Flat P	Flat Q
4		Guitar	Guitar			Guitar	Guitar	
3								
2		Drum		Drum	Drum		Drum	
1								

Clues: E lives to the north-east of F and lives below the one who likes Guitar. D lives to the south of F. A and C live on the same floor.

Inference: We have the following arrangement:

Floors	Case 1		Case 2		Case 3		Case 4	
	Flat P	Flat Q	Flat P	Flat Q	Flat P	Flat Q	Flat P	Flat Q
4	A/C	A/C, Guitar	A/C, Guitar	A/C	A/C,	A/C, Guitar	A/C, Guitar	A/C
3		E		E		E		E
2	F	Drum	F	Drum	F, Drum		F, Drum	
1	D		D		D		D	

Clues: The one who likes sitar lives to the east of A. B lives immediately above G's flat. The one who likes violin lives to the east of H.

Inference: Case 1 and case 3 gets eliminated here because we can't fix sitar position and A.

Floors	Case 1		Case 2		Case 3		Case 4	
	Flat P	Flat Q	Flat P	Flat Q	Flat P	Flat Q	Flat P	Flat Q
4	A/G	A/G, Guitar	A, Guitar	C, Sitar	A/G,	A/G, Guitar	A, Guitar	C, Sitar
3		E	H	E, Violin		E	H	E, Violin
2	F	Drum	F	B, Drum	F, Drum		F, Drum	B
1	D		D	G	D		D	G

Clues: The one who likes Harp lives two floors above the one who likes Piano. The one who likes flute lives to the west of the one who likes Piano. B doesn't like Cello.

Inference: So, case 4 gets eliminated here.

Floors	Case 2		Case 4	
	Flat P	Flat Q	Flat P	Flat Q
4	A, Guitar	C, Sitar	A, Guitar	C, Sitar
3	H, Harp	E, Violin	H, Harp	E, Violin
2	F, Cello	B, Drum	F, Drum	B
1	D, Flute	G, Piano	D, Flute	G, Piano

Inference: Thus, the final arrangement is:

Floors	Flat P	Flat Q
	4	A, Guitar
3	H, Harp	E, Violin
2	F, Cello	B, Drum
1	D, Flute	G, Piano

C likes Sitar.

S7. Ans.(e)

Sol. Final arrangement:

Floors	Flat P	Flat Q
	4	A, Guitar
3	H, Harp	E, Violin
2	F, Cello	B, Drum
1	D, Flute	G, Piano

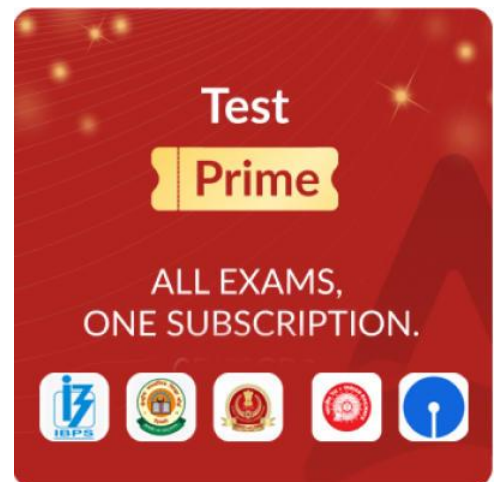

Test Prime

ALL EXAMS,
ONE SUBSCRIPTION.

Logos of various exam bodies: IAS, IFS, IES, IAS, IAS, IAS

Clues: The one who likes Guitar lives two floors above the one who likes Drum. The one who likes drum lives on an even numbered floor.

Inference: We have four possible cases:

Floors	Case 1		Case 2		Case 3		Case 4	
	Flat P	Flat Q	Flat P	Flat Q	Flat P	Flat Q	Flat P	Flat Q
4		Guitar	Guitar			Guitar	Guitar	
3								
2		Drum		Drum	Drum		Drum	
1								

Clues: E lives to the north-east of F and lives below the one who likes Guitar. D lives to the south of F. A and C live on the same floor.

Inference: We have the following arrangement:

Floors	Case 1		Case 2		Case 3		Case 4	
	Flat P	Flat Q	Flat P	Flat Q	Flat P	Flat Q	Flat P	Flat Q
4	A/C	A/C, Guitar	A/C, Guitar	A/C	A/C,	A/C, Guitar	A/C, Guitar	A/C
3		E		E		E		E
2	F	Drum	F	Drum	F, Drum		F, Drum	
1	D		D		D		D	

Clues: The one who likes sitar lives to the east of A. B lives immediately above G's flat. The one who likes violin lives to the east of H.

Inference: Case 1 and case 3 gets eliminated here because we can't fix sitar position and A.

Floors	Case 1		Case 2		Case 3		Case 4	
	Flat P	Flat Q	Flat P	Flat Q	Flat P	Flat Q	Flat P	Flat Q
4	A/C	A/C, Guitar	A, Guitar	C, Sitar	A/C,	A/C, Guitar	A, Guitar	C, Sitar
3		E	H	E, Violin		E	H	E, Violin
2	F	Drum	F	B, Drum	F, Drum		F, Drum	B
1	D		D	G	D		D	G

Clues: The one who likes Harp lives two floors above the one who likes Piano. The one who likes flute lives to the west of the one who likes Piano. B doesn't like Cello.

Inference: So, case 4 gets eliminated here.

Floors	Case 2		Case 4	
	Flat P	Flat Q	Flat P	Flat Q
4	A, Guitar	C, Sitar	A, Guitar	C, Sitar
3	H, Harp	E, Violin	H, Harp	E, Violin
2	F, Cello	B, Drum	F, Drum	B
1	D, Flute	G, Piano	D, Flute	G, Piano

Inference: Thus, the final arrangement is:

Floors	Flat P	Flat Q
	4	A, Guitar
3	H, Harp	E, Violin
2	F, Cello	B, Drum
1	D, Flute	G, Piano

H, the one who likes flute live in the same flat.

S8. Ans.(d)

Sol. Final arrangement:

Floors	Flat P	Flat Q
	4	A, Guitar
3	H, Harp	E, Violin
2	F, Cello	B, Drum
1	D, Flute	G, Piano

Clues: The one who likes Guitar lives two floors above the one who likes Drum. The one who likes drum lives on an even numbered floor.

Inference: We have four possible cases:

Floors	Case 1		Case 2		Case 3		Case 4	
	Flat P	Flat Q	Flat P	Flat Q	Flat P	Flat Q	Flat P	Flat Q
4		Guitar	Guitar			Guitar	Guitar	
3								
2		Drum		Drum	Drum		Drum	
1								

Clues: E lives to the north-east of F and lives below the one who likes Guitar. D lives to the south of F. A and C live on the same floor.

Inference: We have the following arrangement:

Floors	Case 1		Case 2		Case 3		Case 4	
	Flat P	Flat Q	Flat P	Flat Q	Flat P	Flat Q	Flat P	Flat Q
4	A/C	A/C, Guitar	A/C, Guitar	A/C	A/C,	A/C, Guitar	A/C, Guitar	A/C
3		E		E		E		E
2	F	Drum	F	Drum	F, Drum		F, Drum	
1	D		D		D		D	

Clues: The one who likes sitar lives to the east of A. B lives immediately above G's flat. The one who likes violin lives to the east of H.

Inference: Case 1 and case 3 gets eliminated here because we can't fix sitar position and A.

Floors	Case 1		Case 2		Case 3		Case 4	
	Flat P	Flat Q	Flat P	Flat Q	Flat P	Flat Q	Flat P	Flat Q
4	A/G	A/G, Guitar	A, Guitar	C, Sitar	A/G,	A/G, Guitar	A, Guitar	C, Sitar
3		E	H	E, Violin		E	H	E, Violin
2	F	Drum	F	B, Drum	F, Drum		F, Drum	B
1	D		D	G	D		D	G

Clues: The one who likes Harp lives two floors above the one who likes Piano. The one who likes flute lives to the west of the one who likes Piano. B doesn't like Cello.

Inference: So, case 4 gets eliminated here.

Floors	Case 2		Case 4	
	Flat P	Flat Q	Flat P	Flat Q
4	A, Guitar	C, Sitar	A, Guitar	C, Sitar
3	H, Harp	E, Violin	H, Harp	E, Violin
2	F, Cello	B, Drum	F, Drum	B
1	D, Flute	G, Piano	D, Flute	G, Piano

Inference: Thus, the final arrangement is:

Floors	Flat P	Flat Q
	4	A, Guitar
3	H, Harp	E, Violin
2	F, Cello	B, Drum
1	D, Flute	G, Piano

B lives on Floor 2 in flat Q.

S9. Ans.(e)

Sol. Final arrangement:

Floors	Flat P	Flat Q
	4	A, Guitar
3	H, Harp	E, Violin
2	F, Cello	B, Drum
1	D, Flute	G, Piano

Clues: The one who likes Guitar lives two floors above the one who likes Drum. The one who likes drum lives on an even numbered floor.

Inference: We have four possible cases:

Floors	Case 1		Case 2		Case 3		Case 4	
	Flat P	Flat Q	Flat P	Flat Q	Flat P	Flat Q	Flat P	Flat Q
4		Guitar	Guitar			Guitar	Guitar	
3								
2		Drum		Drum	Drum		Drum	
1								

Clues: E lives to the north-east of F and lives below the one who likes Guitar. D lives to the south of F. A and C live on the same floor.

Inference: We have the following arrangement:

Floors	Case 1		Case 2		Case 3		Case 4	
	Flat P	Flat Q	Flat P	Flat Q	Flat P	Flat Q	Flat P	Flat Q
4	A/C	A/C, Guitar	A/C, Guitar	A/C	A/C,	A/C, Guitar	A/C, Guitar	A/C
3		E		E		E		E
2	F	Drum	F	Drum	F, Drum		F, Drum	
1	D		D		D		D	

Clues: The one who likes sitar lives to the east of A. B lives immediately above G's flat. The one who likes violin lives to the east of H.

Inference: Case 1 and case 3 gets eliminated here because we can't fix sitar position and A.

Floors	Case 1		Case 2		Case 3		Case 4	
	Flat P	Flat Q	Flat P	Flat Q	Flat P	Flat Q	Flat P	Flat Q
4	A/G	A/G, Guitar	A, Guitar	C, Sitar	A/G,	A/G, Guitar	A, Guitar	C, Sitar
3		E	H	E, Violin		E	H	E, Violin
2	F	Drum	F	B, Drum	F, Drum		F, Drum	B
1	D		D	G	D		D	G

Clues: The one who likes Harp lives two floors above the one who likes Piano. The one who likes flute lives to the west of the one who likes Piano. B doesn't like Cello.

Inference: So, case 4 gets eliminated here.

Floors	Case 2		Case 4	
	Flat P	Flat Q	Flat P	Flat Q
4	A, Guitar	C, Sitar	A, Guitar	C, Sitar
3	H, Harp	E, Violin	H, Harp	E, Violin
2	F, Cello	B, Drum	F, Drum	B
1	D, Flute	G, Piano	D, Flute	G, Piano

Inference: Thus, the final arrangement is:

Floors	Flat P	Flat Q
4	A, Guitar	C, Sitar
3	H, Harp	E, Violin
2	F, Cello	B, Drum
1	D, Flute	G, Piano

Statement given in option (e) is not true.

S10. Ans.(c)

Sol. Final arrangement:

Floors	Flat P	Flat Q
4	A, Guitar	C, Sitar
3	H, Harp	E, Violin
2	F, Cello	B, Drum
1	D, Flute	G, Piano

Clues: The one who likes Guitar lives two floors above the one who likes Drum. The one who likes drum lives on an even numbered floor.

Inference: We have four possible cases:

Floors	Case 1		Case 2		Case 3		Case 4	
	Flat P	Flat Q	Flat P	Flat Q	Flat P	Flat Q	Flat P	Flat Q
4		Guitar	Guitar			Guitar	Guitar	
3								
2		Drum		Drum	Drum		Drum	
1								

Clues: E lives to the north-east of F and lives below the one who likes Guitar. D lives to the south of F. A and C live on the same floor.

Inference: We have the following arrangement:

Floors	Case 1		Case 2		Case 3		Case 4	
	Flat P	Flat Q	Flat P	Flat Q	Flat P	Flat Q	Flat P	Flat Q
4	A/C	A/C, Guitar	A/C, Guitar	A/C	A/C,	A/C, Guitar	A/C, Guitar	A/C
3		E		E		E		E
2	F	Drum	F	Drum	F, Drum		F, Drum	
1	D		D		D		D	

Clues: The one who likes sitar lives to the east of A. B lives immediately above G's flat. The one who likes violin lives to the east of H.

Inference: Case 1 and case 3 gets eliminated here because we can't fix sitar position and A.

Floors	Case-1		Case 2		Case-3		Case 4	
	Flat P	Flat Q	Flat P	Flat Q	Flat P	Flat Q	Flat P	Flat Q
4	A/G	A/G, Guitar	A, Guitar	C, Sitar	A/G,	A/G, Guitar	A, Guitar	C, Sitar
3		E	H	E, Violin		E	H	E, Violin
2	F	Drum	F	B, Drum	F, Drum		F, Drum	B
1	D		D	G	D		D	G

Clues: The one who likes Harp lives two floors above the one who likes Piano. The one who likes flute lives to the west of the one who likes Piano. B doesn't like Cello.

Inference: So, case 4 gets eliminated here.

Floors	Case 2		Case-4	
	Flat P	Flat Q	Flat P	Flat Q
4	A, Guitar	C, Sitar	A, Guitar	C, Sitar
3	H, Harp	E, Violin	H, Harp	E, Violin
2	F, Cello	B, Drum	F, Drum	B
1	D, Flute	G, Piano	D, Flute	G, Piano

Inference: Thus, the final arrangement is:

Floors	Flat P	Flat Q
	4	A, Guitar
3	H, Harp	E, Violin
2	F, Cello	B, Drum
1	D, Flute	G, Piano

'G- Piano' is the correct combination.

S11. Ans.(b)

Sol. Both statements I and III are sufficient to answer.

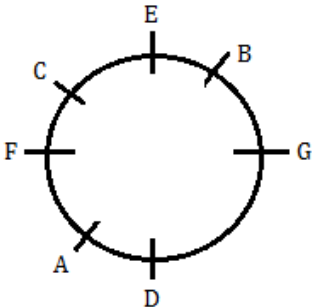

S12. Ans.(a)

Sol. Both statements II and III are sufficient to answer.

Floors	Persons
7	R
6	P
5	T
4	Q
3	V
2	S
1	U

S13. Ans.(d)

Sol. Statement II alone is sufficient to answer.

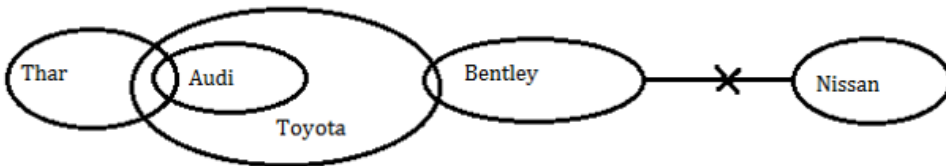

S14. Ans.(e)

Sol. Statements I, II and III even together are not sufficient to answer

S15. Ans.(b)

Sol. Both statements I and III are sufficient to answer

$S > P > T > Q > U > R > V$

S16. Ans.(b)

Sol. Because some part of seed which is land is always restricted to leaf.

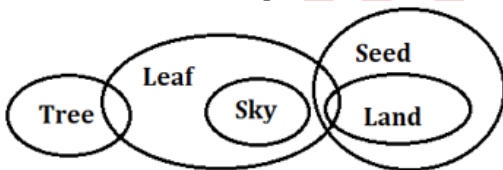

S17. Ans.(a)

Sol.

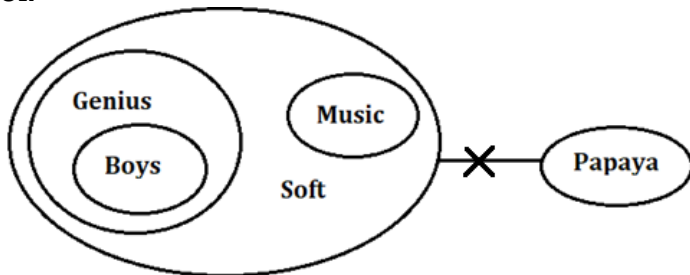

Because music is only related to soft and not with any other elements.

S18. Ans.(e)

Sol. It is definitely said in the statement that some part of cheque is always restricted to digital.

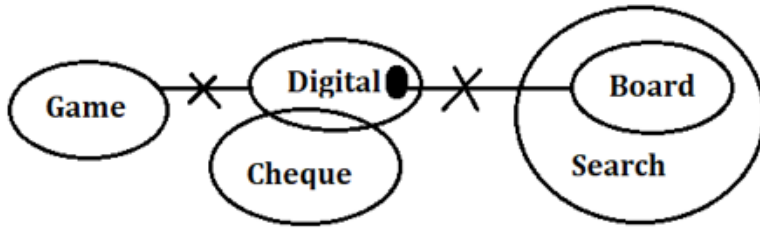

S19. Ans.(d)

Sol. Arrow and mark do not have direct relation, So, their possible relation will follow.

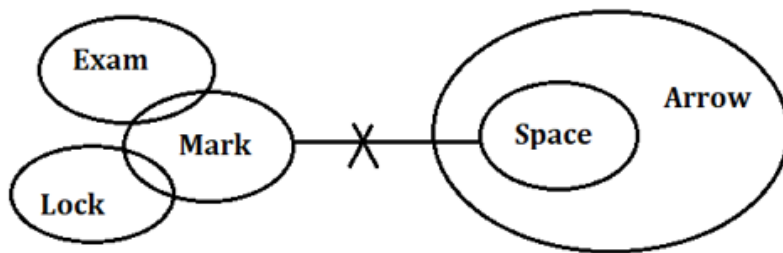

S20. Ans.(c)

Sol. The number after subtracting 1 from the first half of the digits and after the multiplication by 2 of the second half of the digits = 47656846

The number after arranging in descending order from right to left = 44566678

Digits at the even position are 4, 6, 6 and 8.

The sum of the digits at the even position = $4+6+6+8= 24$

S21. Ans.(c)

Sol. Logic: In each step, one number and one word is arranged:

For numbers- Numbers are arranged at the left end in every step, according to the ascending order of resultant of the product of the digits in each number.

For words- Words are arranged at the right end in every step, in descending order of the number of letters in each word.

Input: 66 sanctions 77 flouting 55 reforms 83 anniversary 43 revolution

Step I: 43 66 sanctions 77 flouting 55 reforms 83 revolution anniversary

Step II: 83 43 66 sanctions 77 flouting 55 reforms anniversary revolution

Step III: 55 83 43 66 77 flouting reforms anniversary revolution sanctions

Step IV: 66 55 83 43 77 reforms anniversary revolution sanctions flouting

Step V: 77 66 55 83 43 anniversary revolution sanctions flouting reforms

Second element from the right end in step III is revolution

Third element to the left of revolution is flouting.

S22. Ans.(b)

Sol. Logic: In each step, one number and one word is arranged:

For numbers- Numbers are arranged at the left end in every step, according to the ascending order of resultant of the product of the digits in each number.

For words- Words are arranged at the right end in every step, in descending order of the number of letters in each word.

Input: 66 sanctions 77 flouting 55 reforms 83 anniversary 43 revolution

Step I: 43 66 sanctions 77 flouting 55 reforms 83 revolution anniversary

Step II: 83 43 66 sanctions 77 flouting 55 reforms anniversary revolution

Step III: 55 83 43 66 77 flouting reforms anniversary revolution sanctions

Step IV: 66 55 83 43 77 reforms anniversary revolution sanctions flouting

Step V: 77 66 55 83 43 anniversary revolution sanctions flouting reforms

Third letter of the second word (Sanctions) from the right end is N

Second letter of the first word (Reforms) from the left end is E

Number of letters between N and E are 8

S23. Ans.(d)

Sol. Logic: In each step, one number and one word is arranged:

For numbers- Numbers are arranged at the left end in every step, according to the ascending order of resultant of the product of the digits in each number.

For words- Words are arranged at the right end in every step, in descending order of the number of letters in each word.

Input: 66 sanctions 77 flouting 55 reforms 83 anniversary 43 revolution

Step I: 43 66 sanctions 77 flouting 55 reforms 83 revolution anniversary

Step II: 83 43 66 sanctions 77 flouting 55 reforms anniversary revolution

Step III: 55 83 43 66 77 flouting reforms anniversary revolution sanctions

Step IV: 66 55 83 43 77 reforms anniversary revolution sanctions flouting

Step V: 77 66 55 83 43 anniversary revolution sanctions flouting reforms

In which step V, the order "55 83 43 anniversary revolution sanctions" remains same.

S24. Ans.(a)

Sol. Logic: In each step, one number and one word is arranged:

For numbers- Numbers are arranged at the left end in every step, according to the ascending order of resultant of the product of the digits in each number.

For words- Words are arranged at the right end in every step, in descending order of the number of letters in each word.

Input: 66 sanctions 77 flouting 55 reforms 83 anniversary 43 revolution

Step I: 43 66 sanctions 77 flouting 55 reforms 83 revolution anniversary

Step II: 83 43 66 sanctions 77 flouting 55 reforms anniversary revolution

Step III: 55 83 43 66 77 flouting reforms anniversary revolution sanctions

Step IV: 66 55 83 43 77 reforms anniversary revolution sanctions flouting

Step V: 77 66 55 83 43 anniversary revolution sanctions flouting reforms

Number which is third from the left end in step III is 43

Number which is second from the right end in step I is 55

Required product- $43 * 55 = 2365$

S25. Ans.(e)

Sol. Logic: In each step, one number and one word is arranged:

For numbers- Numbers are arranged at the left end in every step, according to the ascending order of resultant of the product of the digits in each number.

For words- Words are arranged at the right end in every step, in descending order of the number of letters in each word.

Input: 66 sanctions 77 flouting 55 reforms 83 anniversary 43 revolution

Step I: 43 66 sanctions 77 flouting 55 reforms 83 revolution anniversary

Step II: 83 43 66 sanctions 77 flouting 55 reforms anniversary revolution

Step III: 55 83 43 66 77 flouting reforms anniversary revolution sanctions

Step IV: 66 55 83 43 77 reforms anniversary revolution sanctions flouting

Step V: 77 66 55 83 43 anniversary revolution sanctions flouting reforms

Sum of the elements which are second, third and fifth from the left end in step II is $(43+66+77) = 186$.

S26. Ans.(e)

Sol. From the given statements, Tanmay sits third to the left of Diya's brother and fourth to the right of Diya.

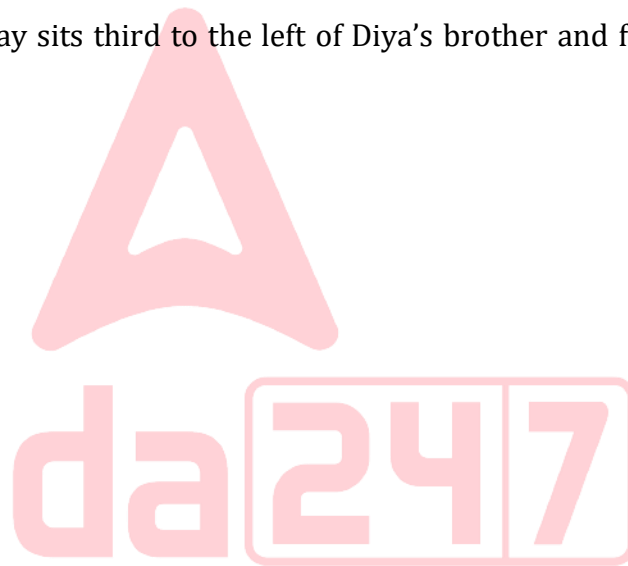
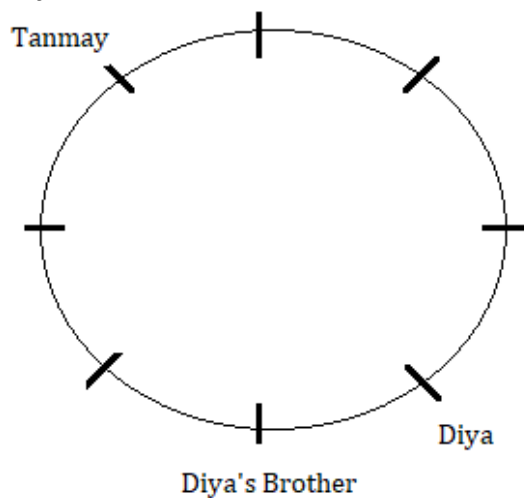

Paras's father sits immediate left of Diya's daughter-in-law. Ganesh is brother of Tanmay and Paras is grandson of Diya. Diya's son (except Ganesh) orders Chana masala while Diya orders Doughy and speaks English language. Diya's grandson is sitting exact opposite of Diya's daughter-in-law who orders Fish curry. The Persons who order Empanadas and Doughy speak English language.

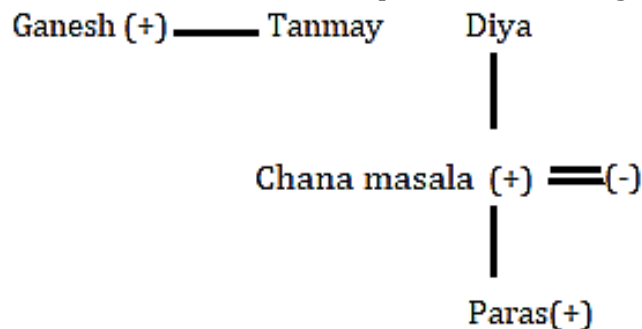

Diya has two grandchildren and two sons. Only Arti and Palak speak Hindi language. Ravi's brother-in-law orders Hamburger and speaks Spanish language. Ravi has two sons. Arti is the mother of Palak and sits third to the right of Palak. Ganesh's father orders Gumbo and speaks English language also sits immediate right of Palak who is sister of Paras. Suresh is the maternal uncle of Tanmay. Tanmay's brother orders Aloo paratha. Ganesh speaks the same language as Tanmay.

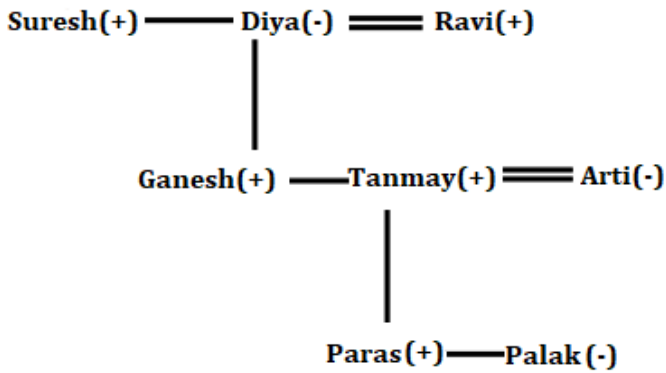

After the blood relation and the above information the final arrangement is-

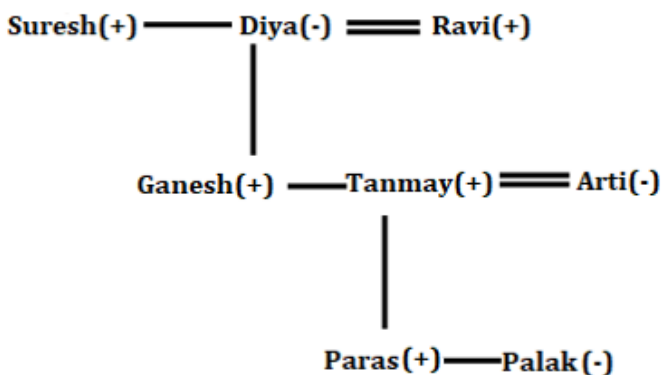
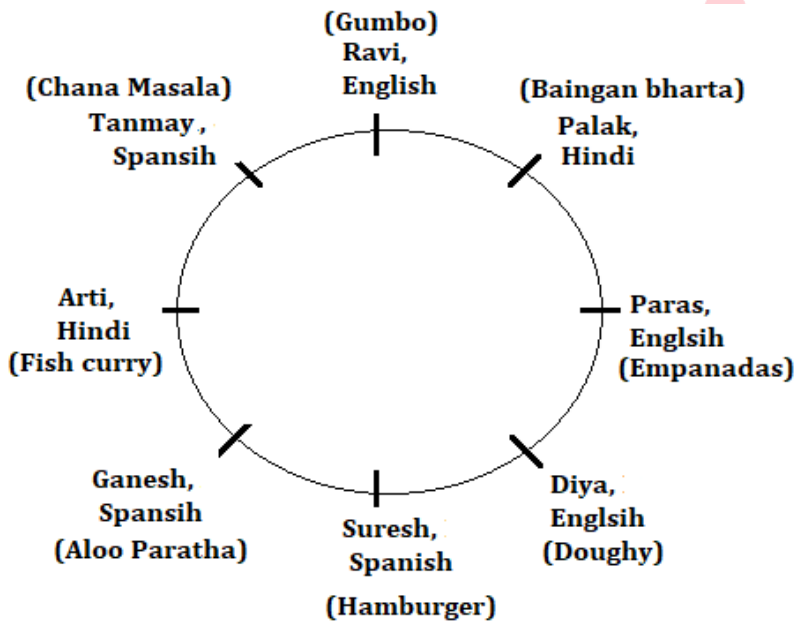

Four persons sit between Palak and the one who orders Hamburger when counted from the right of Palak

S27. Ans.(a)

Sol. From the given statements, Tanmay sits third to the left of Diya's brother and fourth to the right of Diya.

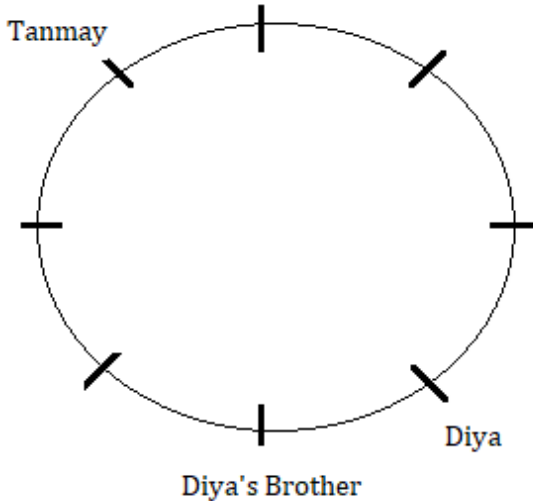

Paras's father sits immediate left of Diya's daughter-in-law. Ganesh is brother of Tanmay and Paras is grandson of Diya. Diya's son (except Ganesh) orders Chana masala while Diya orders Doughy and speaks English language. Diya's grandson is sitting exact opposite of Diya's daughter-in-law who orders Fish curry. The Persons who order Empanadas and Doughy speak English language.

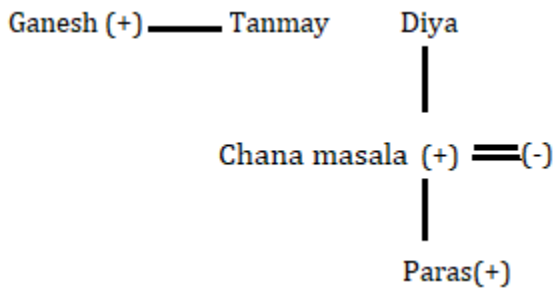

Diya has two grandchildren and two sons. Only Arti and Palak speak Hindi language. Ravi's brother-in-law orders Hamburger and speaks Spanish language. Ravi has two sons. Arti is the mother of Palak and sits third to the right of Palak. Ganesh's father orders Gumbo and speaks English language also sits immediate right of Palak who is sister of Paras. Suresh is the maternal uncle of Tanmay. Tanmay's brother orders Aloo paratha. Ganesh speaks the same language as Tanmay.

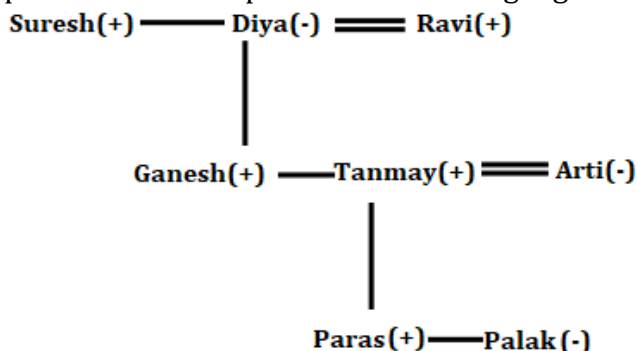

After the blood relation and the above information the final arrangement is-

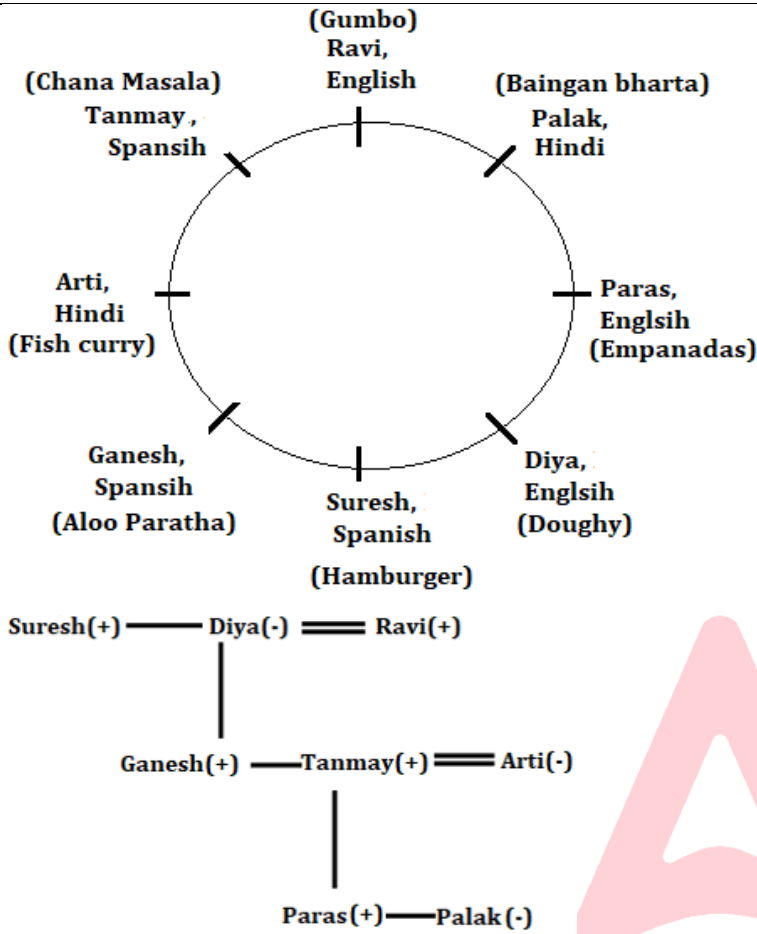

- I. Tanmay does not speak English (**Correct**)
- II. Ravi is the father of Palak (**Incorrect**)
- III. Suresh order empanadas (**Incorrect**)

S28. Ans.(b)

Sol. From the given statements, Tanmay sits third to the left of Diya's brother and fourth to the right of Diya.

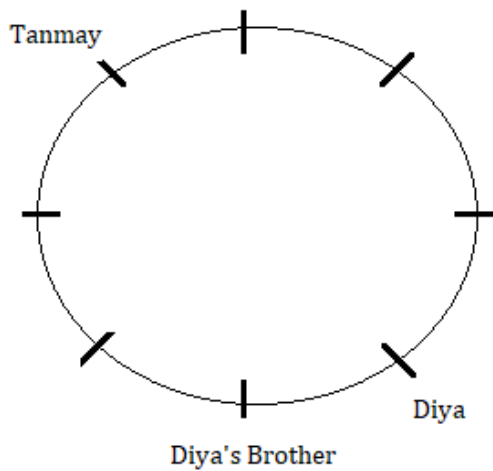

Paras's father sits immediate left of Diya's daughter-in-law. Ganesh is brother of Tanmay and Paras is grandson of Diya. Diya's son (except Ganesh) orders Chana masala while Diya orders Doughy and speaks English language. Diya's grandson is sitting exact opposite of Diya's daughter-in-law who orders Fish curry. The Persons who order Empanadas and Doughy speak English language.

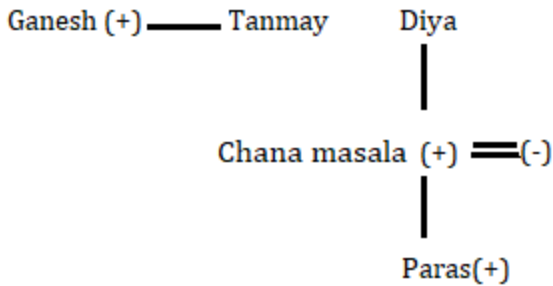

Diya has two grandchildren and two sons. Only Arti and Palak speak Hindi language. Ravi's brother-in-law orders Hamburger and speaks Spanish language. Ravi has two sons. Arti is the mother of Palak and sits third to the right of Palak. Ganesh's father orders Gumbo and speaks English language also sits immediate right of Palak who is sister of Paras. Suresh is the maternal uncle of Tanmay. Tanmay's brother orders Aloo paratha. Ganesh speaks the same language as Tanmay.

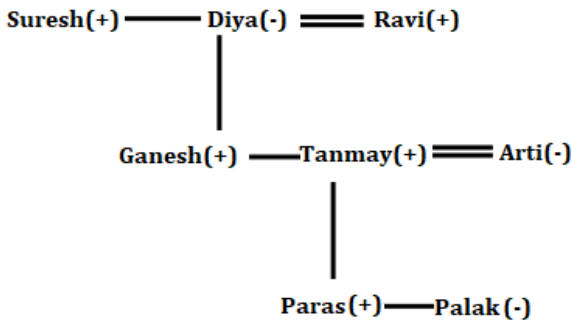

After the blood relation and the above information the final arrangement is-

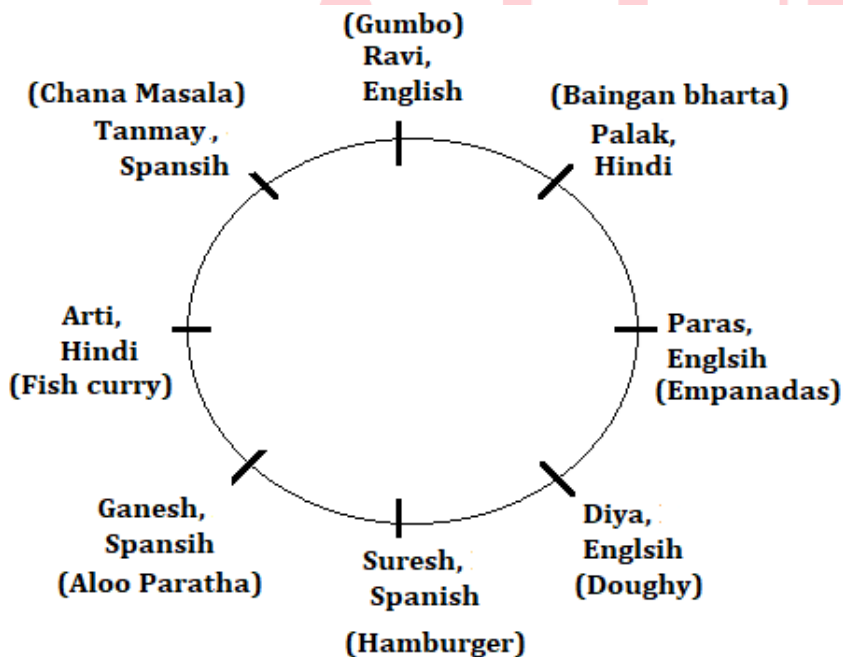

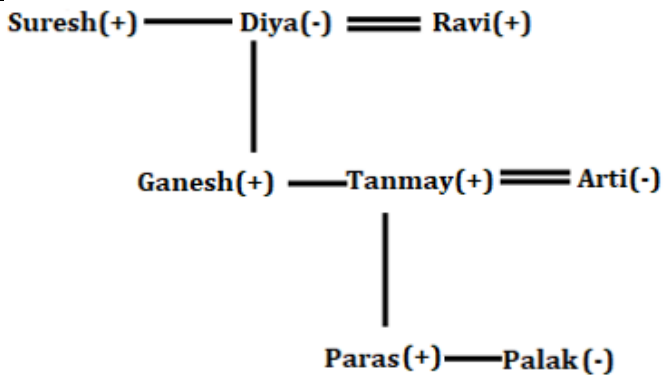

Three persons remain unchanged - Palak, Paras and Suresh

S29. Ans.(c)

Sol. From the given statements, Tanmay sits third to the left of Diya's brother and fourth to the right of Diya.

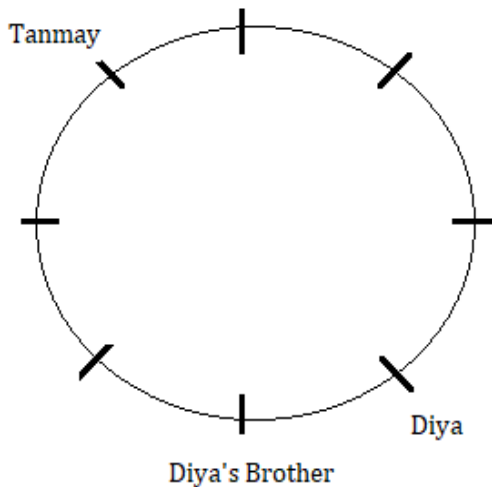

Paras's father sits immediate left of Diya's daughter-in-law. Ganesh is brother of Tanmay and Paras is grandson of Diya. Diya's son (except Ganesh) orders Chana masala while Diya orders Doughy and speaks English language. Diya's grandson is sitting exact opposite of Diya's daughter-in-law who orders Fish curry. The Persons who order Empanadas and Doughy speak English language.

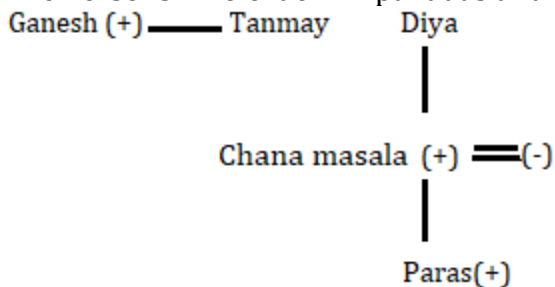

Diya has two grandchildren and two sons. Only Arti and Palak speak Hindi language. Ravi's brother-in-law orders Hamburger and speaks Spanish language. Ravi has two sons. Arti is the mother of Palak and sits third to the right of Palak. Ganesh's father orders Gumbo and speaks English language also sits immediate right of Palak who is sister of Paras. Suresh is the maternal uncle of Tanmay. Tanmay's brother orders Aloo paratha. Ganesh speaks the same language as Tanmay.

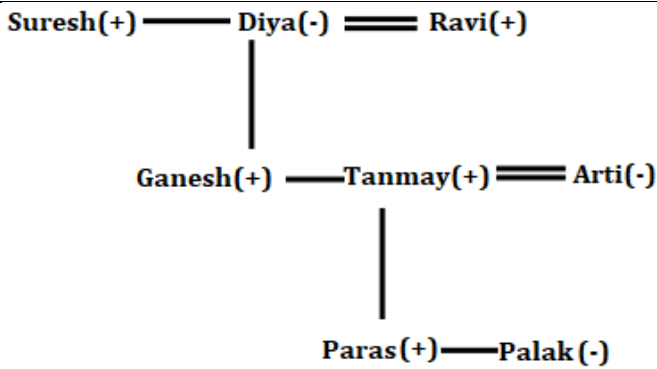

After the blood relation and the above information the final arrangement is-

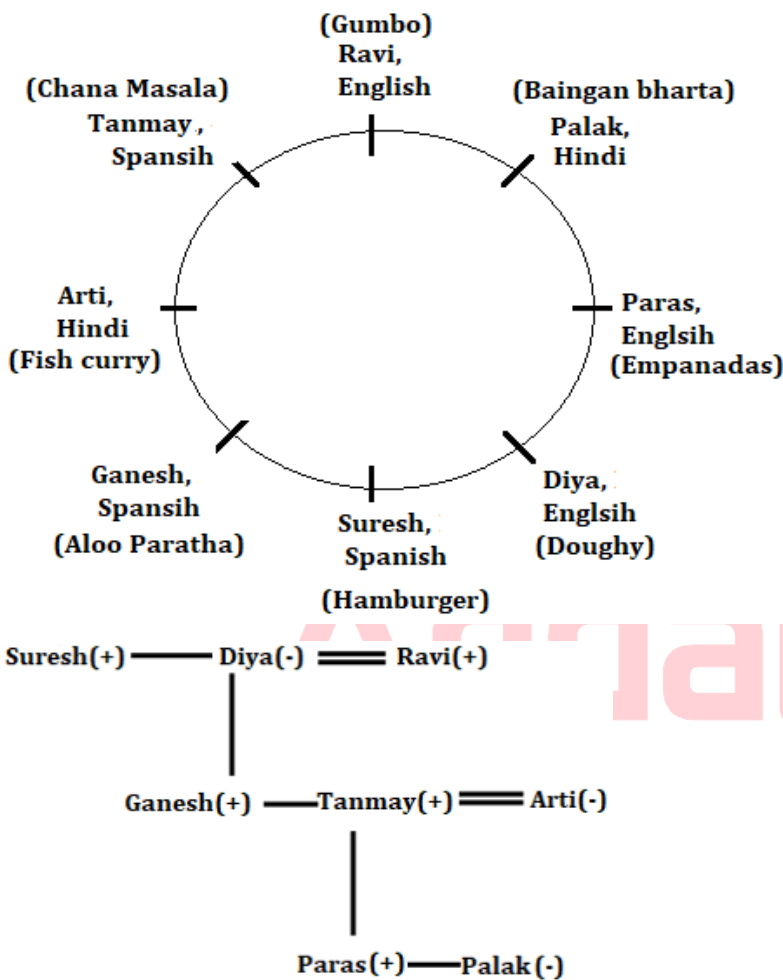

Arti's brother-in-law (Ganesh) sits 7th to the right of Tanmay's uncle (Suresh)

S30. Ans.(e)

Sol. From the given statements, Tanmay sits third to the left of Diya's brother and fourth to the right of Diya.

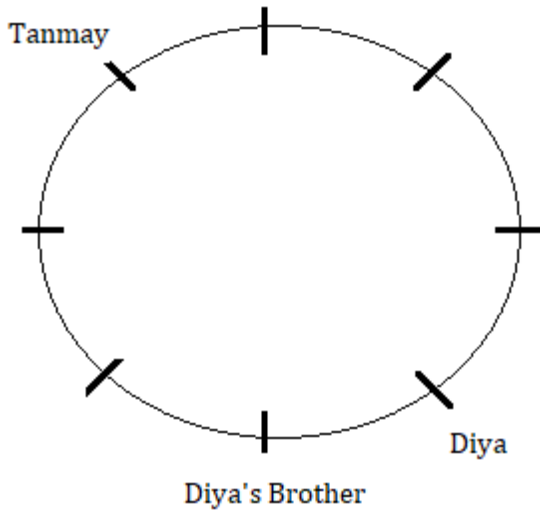

Paras's father sits immediate left of Diya's daughter-in-law. Ganesh is brother of Tanmay and Paras is grandson of Diya. Diya's son (except Ganesh) orders Chana masala while Diya orders Doughy and speaks English language. Diya's grandson is sitting exact opposite of Diya's daughter-in-law who orders Fish curry. The Persons who order Empanadas and Doughy speak English language.

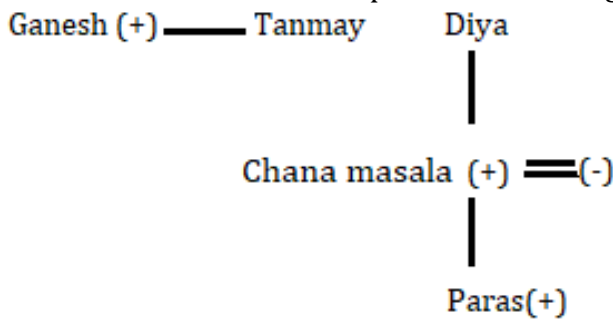

Diya has two grandchildren and two sons. Only Arti and Palak speak Hindi language. Ravi's brother-in-law orders Hamburger and speaks Spanish language. Ravi has two sons. Arti is the mother of Palak and sits third to the right of Palak. Ganesh's father orders Gumbo and speaks English language also sits immediate right of Palak who is sister of Paras. Suresh is the maternal uncle of Tanmay. Tanmay's brother orders Aloo paratha. Ganesh speaks the same language as Tanmay.

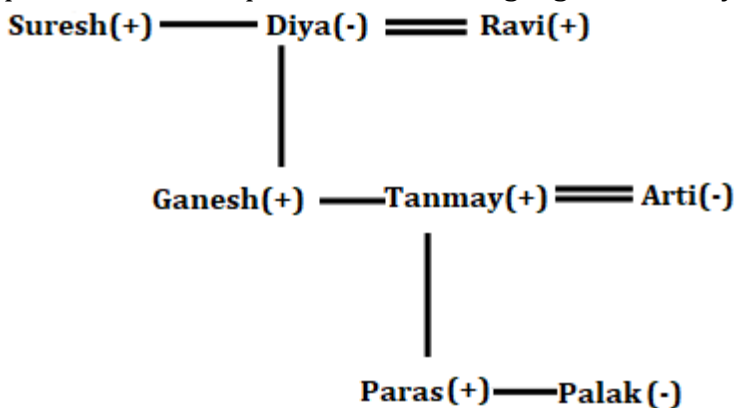

After the blood relation and the above information the final arrangement is-

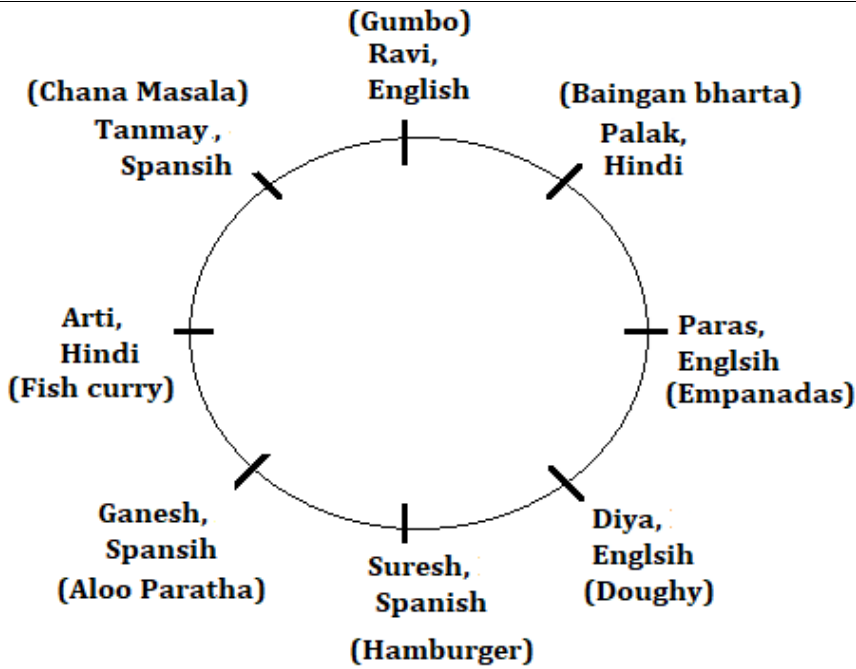

Suresh(+) — Diya(-) == Ravi(+)

Ganesh(+) — Tanmay(+) == Arti(-)

Paras(+) — Palak(-)

All of them male except Diya

S31. Ans.(c)

Sol.

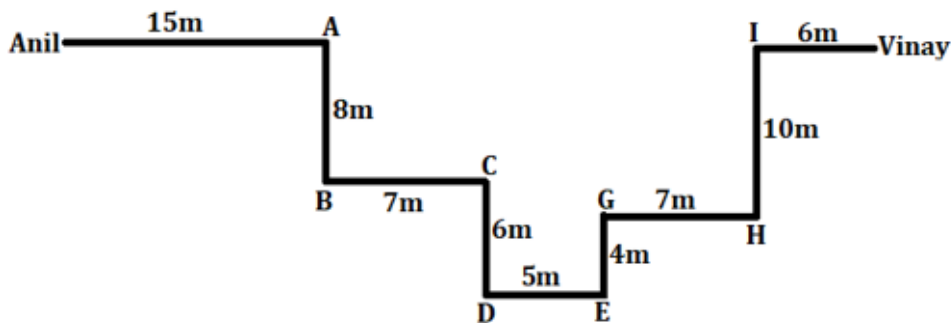

Point A is in the north-west direction of point E

S32. Ans.(b)

Sol.

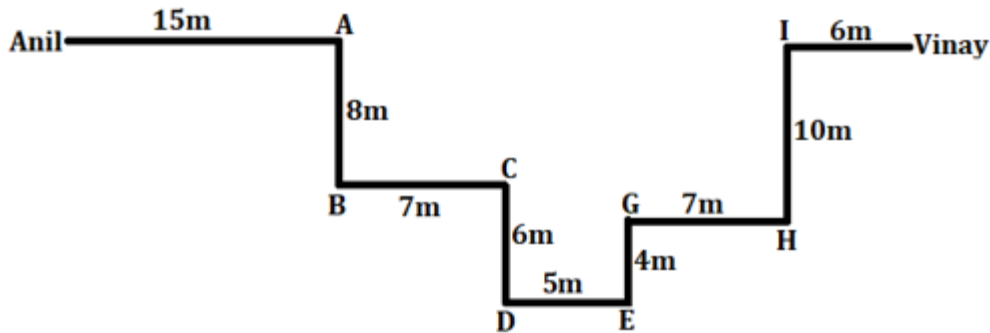

The total distance between point B and point H is 29m

S33. Ans.(d)

Sol.

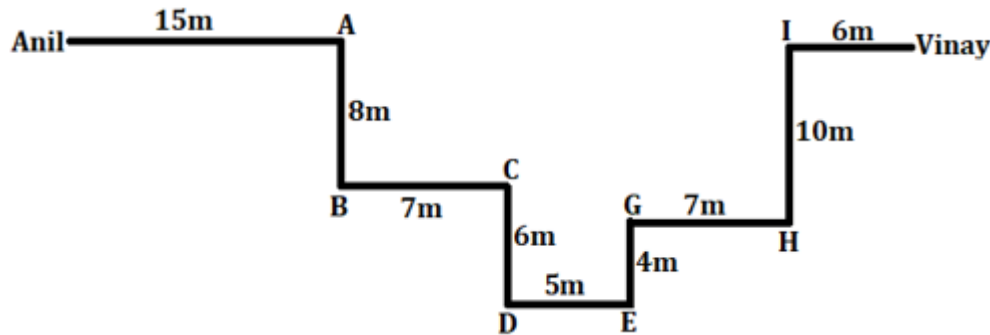

Point A is in the west of Vinay's starting point

S34. Ans.(c)

Sol.

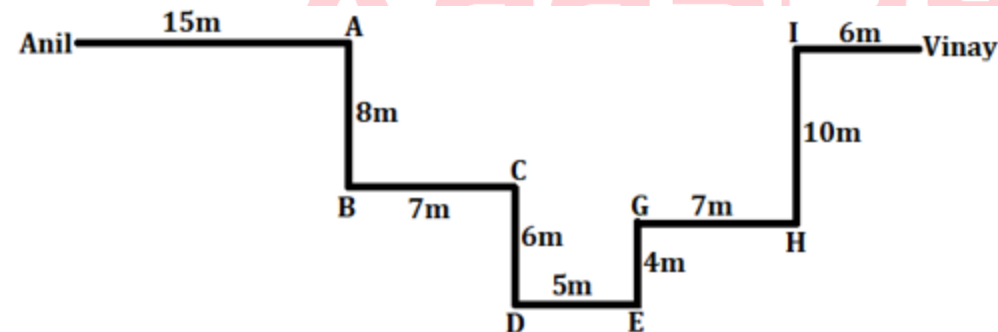

The shortest distance between Anil's starting point and point B is 17m

S35. Ans.(a)

Sol. Given word- INCANDESCENT

After arrangement-LLADLBHQHLR

AABDHLLLLQR

Letters between L and D, are 7

S36. Ans.(c)

Sol. Final arrangement:

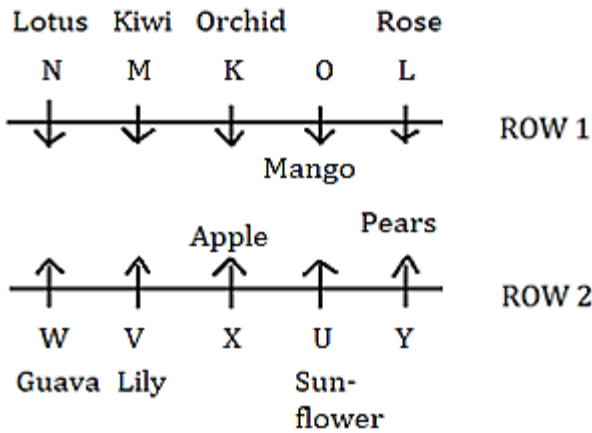

Clues- O likes mango and sits third to the left of N who likes lotus. Only one person sits between O and M. X faces the one who sits second to the left of the one who likes lotus.

Inference- So, here we have two possible cases i.e., case1 and case2.

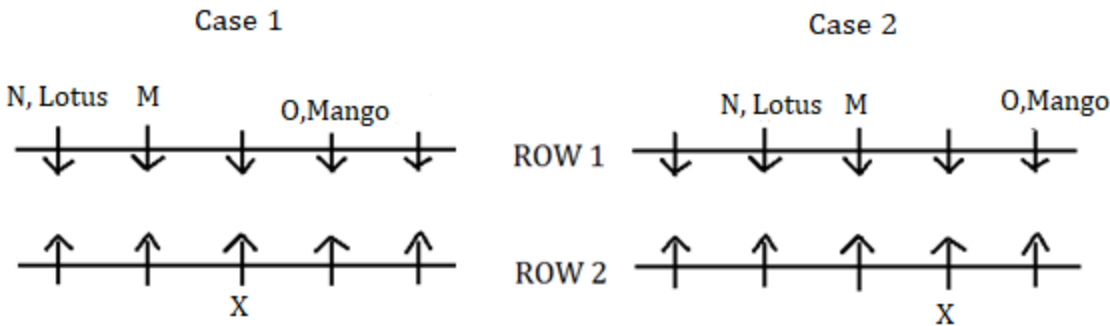

Clues- The one who likes rose faces the one who sits third to the right of the one who likes lily. The one who likes lily faces north. The one who likes kiwi faces the one who sits third to the left of Y. Y likes fruit and sits at one of the extreme ends. The one who likes orchid faces the one who sits second to the right of the one who likes guava.

Inference- As we know that persons sitting adjacent to each other doesn't like same things (either fruit or flower) so the one who likes orchid sits in row 1. So, case 2 gets eliminated here.

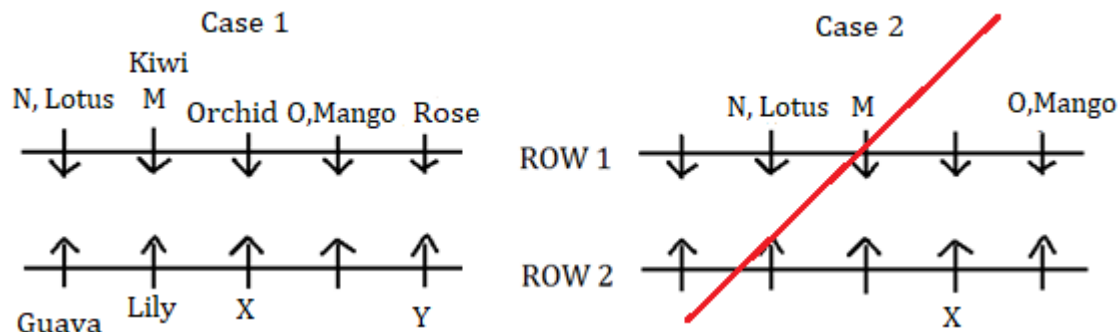

Clues- Y doesn't like apple. U likes flower but not lily. W sits second to the left of the one who faces K.

Inference- From the above statements which means X likes apple and Y likes Pears. U likes sunflower. X faces K who likes orchid. V likes lily and L likes rose. And the final arrangement is given below.

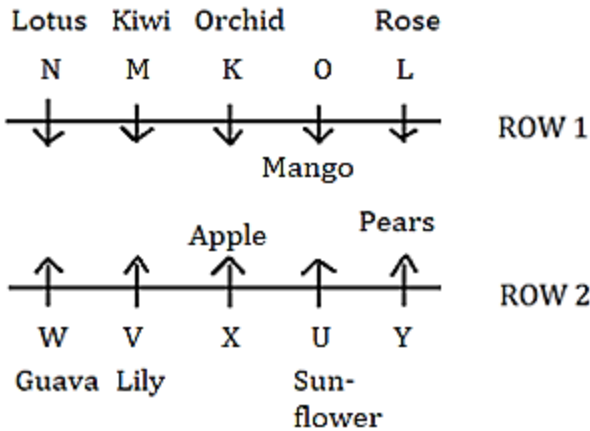

The one who sits at immediate left of O i.e., L likes rose.

S37. Ans.(b)

Sol. Final arrangement:

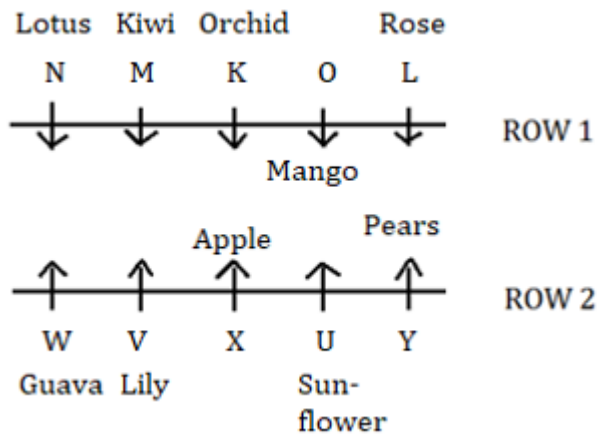

Clues- O likes mango and sits third to the left of N who likes lotus. Only one person sits between O and M. X faces the one who sits second to the left of the one who likes lotus.

Inference- So, here we have two possible cases i.e., case1 and case2.

Case 1

Case 2

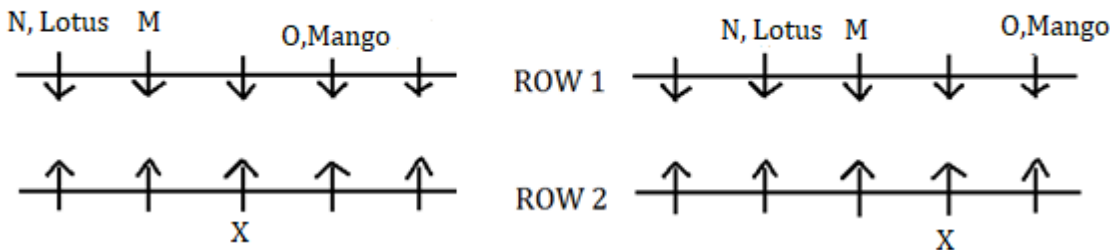

Clues- The one who likes rose faces the one who sits third to the right of the one who likes lily. The one who likes lily faces north. The one who likes kiwi faces the one who sits third to the left of Y. Y likes fruit and sits at one of the extreme ends. The one who likes orchid faces the one who sits second to the right of the one who likes guava.

Inference-As we know that persons sitting adjacent to each other doesn't like same things (either fruit or flower) so the one who likes orchid sits in row 1. So, case 2 gets eliminated here.

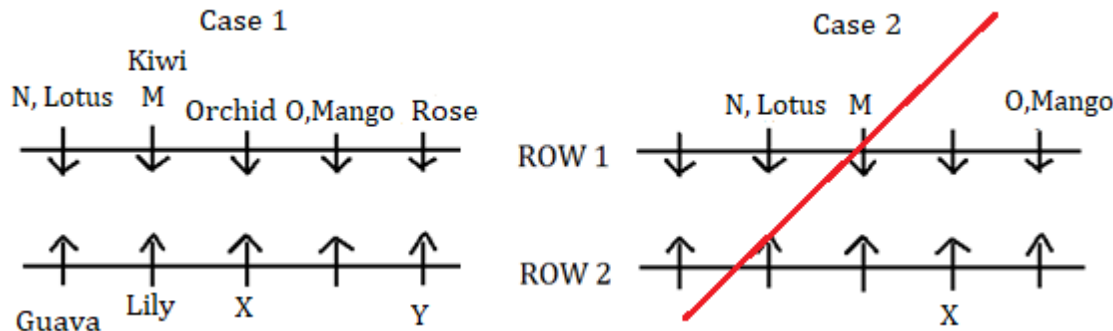

Clues- Y doesn't like apple. U likes flower but not lily. W sits second to the left of the one who faces K.

Inference-From the above statements which means X likes apple and Y likes Pears. U likes sunflower. X faces K who likes orchid. V likes lily and L likes rose. And the final arrangement is given below.

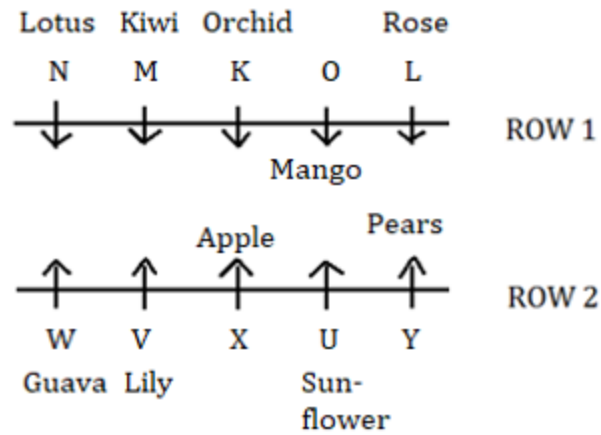

Two persons are sitting between N and the one who likes mango

S38. Ans.(e)

Sol. Final arrangement:

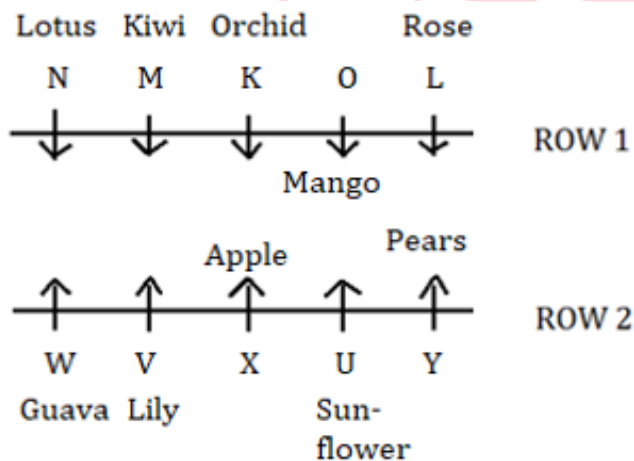

Clues- O likes mango and sits third to the left of N who likes lotus. Only one person sits between O and M. X faces the one who sits second to the left of the one who likes lotus.

Inference- So, here we have two possible cases i.e., case1 and case2.

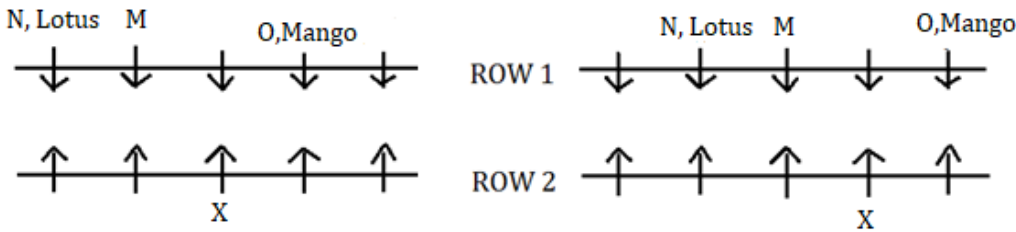

Clues- The one who likes rose faces the one who sits third to the right of the one who likes lily. The one who likes lily faces north. The one who likes kiwi faces the one who sits third to the left of Y. Y likes fruit and sits at one of the extreme ends. The one who likes orchid faces the one who sits second to the right of the one who likes guava.

Inference- As we know that persons sitting adjacent to each other doesn't like same things (either fruit or flower) so the one who likes orchid sits in row 1. So, case 2 gets eliminated here.

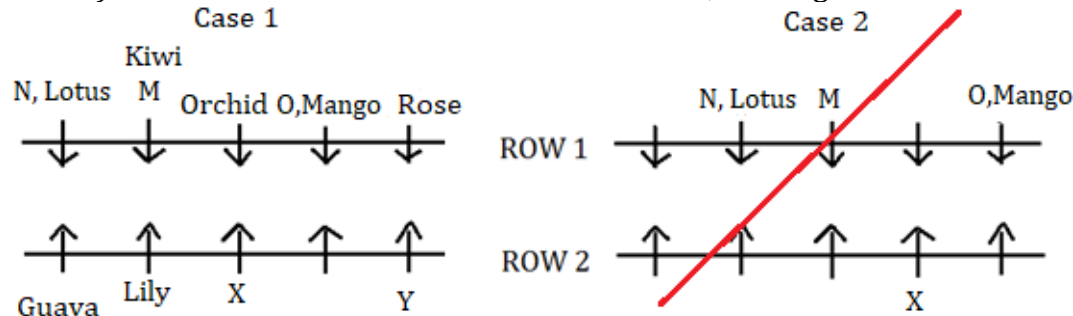

Clues- Y doesn't like apple. U likes flower but not lily. W sits second to the left of the one who faces K.

Inference- From the above statements which means X likes apple and Y likes Pears. U likes sunflower. X faces K who likes orchid. V likes lily and L likes rose. And the final arrangement is given below.

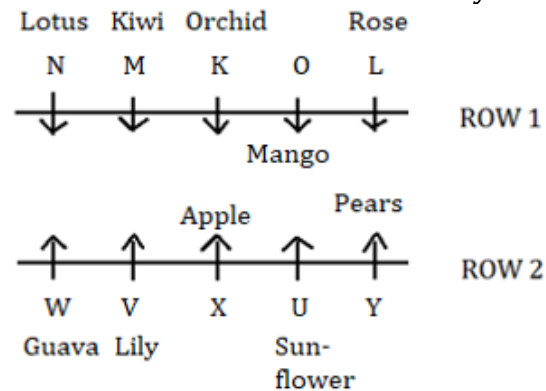

All of them sit in row 1 except V

S39. Ans.(d)

Sol. Final arrangement:

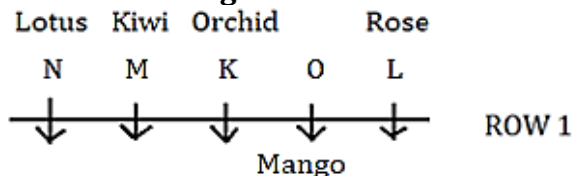

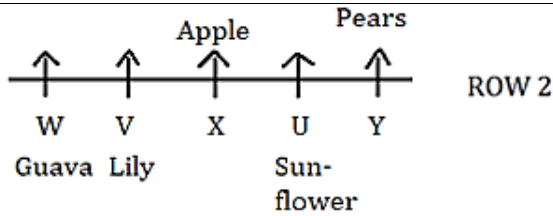

Clues- O likes mango and sits third to the left of N who likes lotus. Only one person sits between O and M. X faces the one who sits second to the left of the one who likes lotus.

Inference- So, here we have two possible cases i.e., case1 and case2.

Case 1

Case 2

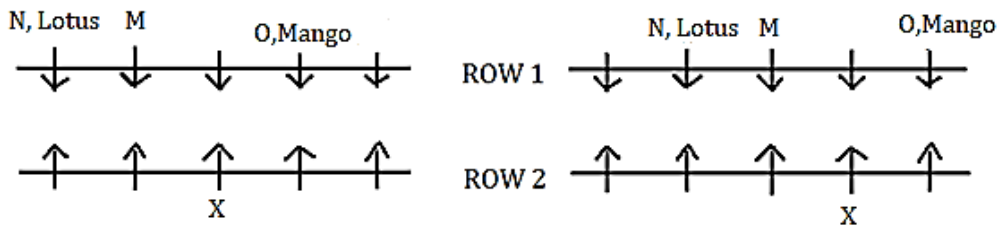

Clues- The one who likes rose faces the one who sits third to the right of the one who likes lily. The one who likes lily faces north. The one who likes kiwi faces the one who sits third to the left of Y. Y likes fruit and sits at one of the extreme ends. The one who likes orchid faces the one who sits second to the right of the one who likes guava.

Inference- As we know that persons sitting adjacent to each other doesn't like same things (either fruit or flower) so the one who likes orchid sits in row 1. So, case 2 gets eliminated here.

Case 1

Case 2

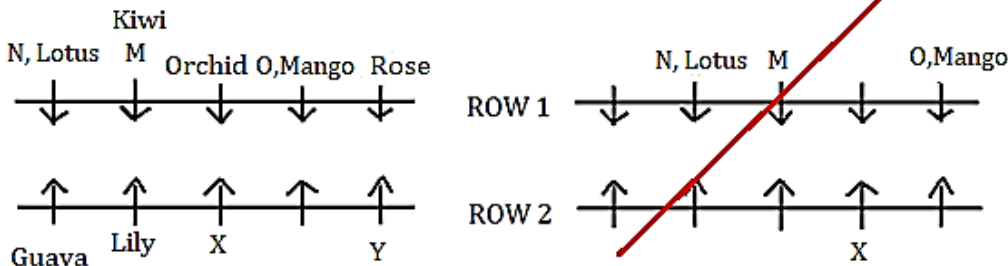

Clues- Y doesn't like apple. U likes flower but not lily. W sits second to the left of the one who faces K.

Inference- From the above statements which means X likes apple and Y likes Pears. U likes sunflower. X faces K who likes orchid. V likes lily and L likes rose. And the final arrangement is given below.

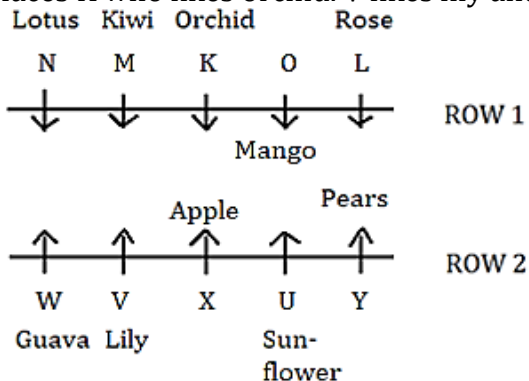

Option (d) is not true

S40. Ans.(a)

Sol. Final arrangement:

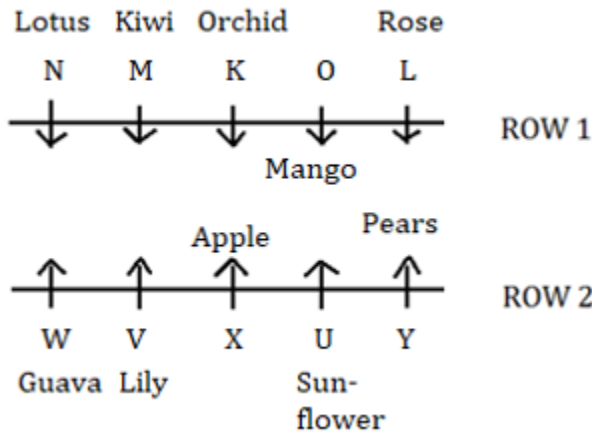

Clues- O likes mango and sits third to the left of N who likes lotus. Only one person sits between O and M. X faces the one who sits second to the left of the one who likes lotus.

Inference- So, here we have two possible cases i.e., case1 and case2.

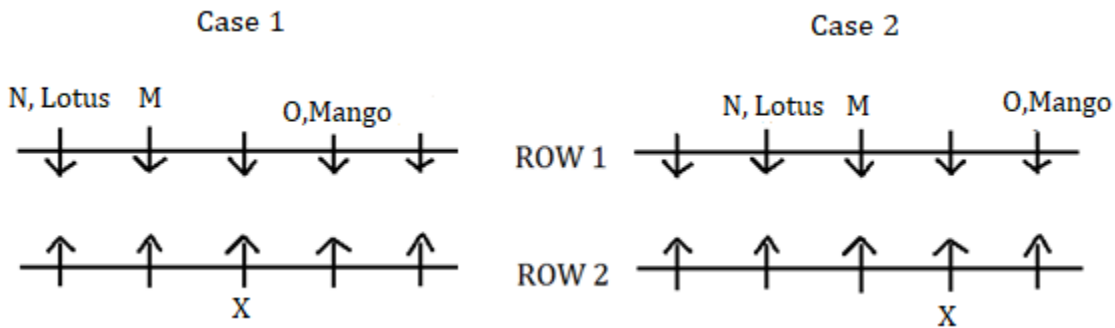

Clues- The one who likes rose faces the one who sits third to the right of the one who likes lily. The one who likes lily faces north. The one who likes kiwi faces the one who sits third to the left of Y. Y likes fruit and sits at one of the extreme ends. The one who likes orchid faces the one who sits second to the right of the one who likes guava.

Inference- As we know that persons sitting adjacent to each other doesn't like same things (either fruit or flower) so the one who likes orchid sits in row 1. So, case 2 gets eliminated here.

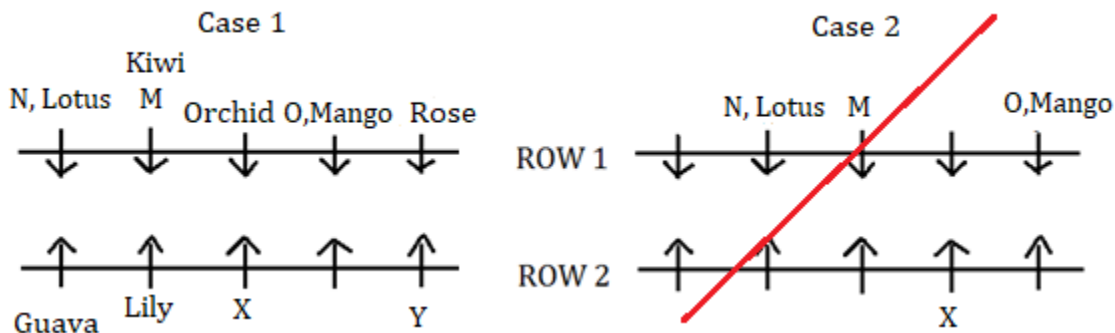

Clues- Y doesn't like apple. U likes flower but not lily. W sits second to the left of the one who faces K.

Inference- From the above statements which means X likes apple and Y likes Pears. U likes sunflower. X faces K who likes orchid. V likes lily and L likes rose. And the final arrangement is given below.

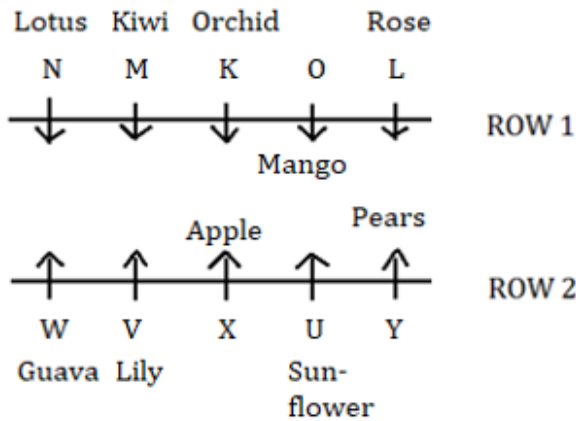

The one who likes kiwi sits third to the right of the one who faces Y

S41. Ans.(b)

Sol.

Sections	Total students	Students went on a trip	Students did not go on a trip
A	50	$\frac{40}{100} \times 50 = 20$	$(50 - 20) = 30$
B	40	$\frac{60}{100} \times 40 = 24$	$(40 - 24) = 16$
C	60	$\frac{35}{100} \times 60 = 21$	$(60 - 21) = 39$
D	55	$\frac{80}{100} \times 55 = 44$	$(55 - 44) = 11$

Required ratio = $\frac{24+44}{41} = 68:41$

S42. Ans.(c)

Sol.

Sections	Total students	Students went on a trip	Students did not go on a trip
A	50	$\frac{40}{100} \times 50 = 20$	$(50 - 20) = 30$
B	40	$\frac{60}{100} \times 40 = 24$	$(40 - 24) = 16$
C	60	$\frac{35}{100} \times 60 = 21$	$(60 - 21) = 39$
D	55	$\frac{80}{100} \times 55 = 44$	$(55 - 44) = 11$

Number of boys in section A = $\frac{2}{5} \times 50 = 20$

Number of girls in section A = $50 - 20 = 30$

Number of boys in D = $\frac{5}{11} \times 55 = 25$

Number of girls in D = $55 - 25 = 30$

Number of boys who did not went on a trip from A = $20 - 10 = 10$

Number of girls who did not went on a trip from D = $30 - 25 = 5$

Number of boys who did not went on a trip from D = $11 - 5 = 6$

Required sum = $10 + 6 = 16$

S43. Ans.(a)

Sol.

Sections	Total students	Students went on a trip	Students did not go on a trip
A	50	$\frac{40}{100} \times 50 = 20$	$(50 - 20) = 30$
B	40	$\frac{60}{100} \times 40 = 24$	$(40 - 24) = 16$
C	60	$\frac{35}{100} \times 60 = 21$	$(60 - 21) = 39$
D	55	$\frac{80}{100} \times 55 = 44$	$(55 - 44) = 11$

Required average = $\frac{30+16+39+11}{4} = 24$

S44. Ans.(d)

Sol.

Sections	Total students	Students went on a trip	Students did not go on a trip
A	50	$\frac{40}{100} \times 50 = 20$	$(50 - 20) = 30$
B	40	$\frac{60}{100} \times 40 = 24$	$(40 - 24) = 16$
C	60	$\frac{35}{100} \times 60 = 21$	$(60 - 21) = 39$
D	55	$\frac{80}{100} \times 55 = 44$	$(55 - 44) = 11$

Number of girls who did not go on a trip from A = $\frac{2}{5} \times 30 = 12$

Number of boys who did not go on a trip from A = $30 - 12 = 18$

Number of girls who did not go on a trip from B = $\frac{3}{4} \times 16 = 12$

Number of boys who did not go on a trip from B = $16 - 12 = 4$

Number of girls who did not go on a trip from D = $\frac{6}{11} \times 11 = 6$

Number of boys who did not go on a trip from D = $11 - 6 = 5$

Number of boys who did not go on a trip from C = $54 - 18 - 4 - 5 = 27$

Number of girls who did not go on a trip from C = $39 - 27 = 12$

S45. Ans.(e)

Sol.

Sections	Total students	Students went on a trip	Students did not go on a trip
A	50	$\frac{40}{100} \times 50 = 20$	$(50 - 20) = 30$
B	40	$\frac{60}{100} \times 40 = 24$	$(40 - 24) = 16$
C	60	$\frac{35}{100} \times 60 = 21$	$(60 - 21) = 39$
D	55	$\frac{80}{100} \times 55 = 44$	$(55 - 44) = 11$

For section A

Let the number of boys in A be x and number of girls be y

$$x + y = 50$$

$$x - y = 10$$

$$x = 30$$

$$y = 20$$

For section C

Let the number of boys in C be p and number of girls be q

$$p + q = 60$$

$$p - q = 20$$

$$p = 40$$

$$q = 20$$

For A

$$\text{Number of boys did not go on a trip} = \frac{7}{10} \times 30 = 21$$

$$\text{Number of girls who did not go on a trip} = 30 - 21 = 9$$

For C

$$\text{Number of girls who did not go on a trip} = \frac{60}{100} \times 20 = 12$$

$$\text{Required percentage} = \frac{9+12}{50} \times 100 = 42\%$$



S46. Ans.(a)

Sol.

$$\text{Total number of males in all the village} = \frac{100}{24-20} \times 80 = 2000$$

Villages	Males	Females	Total
A	$\frac{24}{100} \times 2000 = 480$	$480 - 180 = 300$	780
B	$\frac{38}{100} \times 2000 = 760$	$760 - 210 = 550$	1310
C	$\frac{20}{100} \times 2000 = 400$	$400 - 250 = 150$	550
D	$\frac{18}{100} \times 2000 = 360$	$360 - 160 = 200$	560

$$\text{Required ratio} = \frac{480+400}{550+200} = \frac{880}{750} = 88:75$$

S47. Ans.(d)

Sol.

$$\text{Total number of males in all the village} = \frac{100}{24-20} \times 80 = 2000$$

Villages	Males	Females	Total
A	$\frac{24}{100} \times 2000 = 480$	$480 - 180 = 300$	780
B	$\frac{38}{100} \times 2000 = 760$	$760 - 210 = 550$	1310
C	$\frac{20}{100} \times 2000 = 400$	$400 - 250 = 150$	550
D	$\frac{18}{100} \times 2000 = 360$	$360 - 160 = 200$	560

$$\text{Required percentage} = \frac{480-400}{400} \times 100 = 20\%$$

S48. Ans.(e)

Sol.

$$\text{Total number of males in all the village} = \frac{100}{24-20} \times 80 = 2000$$

Villages	Males	Females	Total
A	$\frac{24}{100} \times 2000 = 480$	$480 - 180 = 300$	780
B	$\frac{38}{100} \times 2000 = 760$	$760 - 210 = 550$	1310
C	$\frac{20}{100} \times 2000 = 400$	$400 - 250 = 150$	550
D	$\frac{18}{100} \times 2000 = 360$	$360 - 160 = 200$	560

$$\text{Total number of females} = 300 + 550 + 150 + 200 = 1200$$

$$\text{Degree of number of females in D} = \frac{200}{1200} \times 360 = 60^\circ$$

$$\text{Degree of the number of females in C} = \frac{150}{1200} \times 360 = 45^\circ$$

$$\text{Required difference} = 60^\circ - 45^\circ = 15^\circ$$

S49. Ans.(a)

Sol.

$$\text{Total number of males in all the village} = \frac{100}{24-20} \times 80 = 2000$$

Villages	Males	Females	Total
A	$\frac{24}{100} \times 2000 = 480$	$480 - 180 = 300$	780
B	$\frac{38}{100} \times 2000 = 760$	$760 - 210 = 550$	1310
C	$\frac{20}{100} \times 2000 = 400$	$400 - 250 = 150$	550
D	$\frac{18}{100} \times 2000 = 360$	$360 - 160 = 200$	560

Number of people worked in rural area from A = $\frac{5}{13} \times 780 = 300$

Required difference = $360 - 300 = 60$

S50. Ans.(b)

Sol.

Total number of males in all the village = $\frac{100}{24-20} \times 80 = 2000$

Villages	Males	Females	Total
A	$\frac{24}{100} \times 2000 = 480$	$480 - 180 = 300$	780
B	$\frac{38}{100} \times 2000 = 760$	$760 - 210 = 550$	1310
C	$\frac{20}{100} \times 2000 = 400$	$400 - 250 = 150$	550
D	$\frac{18}{100} \times 2000 = 360$	$360 - 160 = 200$	560

Required average = $\frac{780+1310+550+560}{4} = 800$

S51. Ans.(e)

Sol.

For J&K, Total enrolled students = 50000

Total rejected students = $50000 \times \frac{10}{100} = 5000$

Total appeared students = $(50000 - 5000) \times \frac{5}{9} = 25000$

Total non-appeared students = $45000 - 25000 = 20000$

Similarly, for others states too,

States	Total students enrolled	Total rejected students	Appeared students	Non-appeared students
J&K	50000	5000	25000	20000
MP	60000	18000	30000	12000
UP	48000	12000	27000	9000
HP	32000	8000	16000	8000
UK	20000	3000	10000	7000

Required difference = $12000 - 10000 = 2000$

S52. Ans.(a)

Sol.

For J&K, Total enrolled students= 50000

Total rejected students= $50000 \times \frac{10}{100} = 5000$

Total appeared students= $(50000 - 5000) \times \frac{5}{9} = 25000$

Total non-appeared students= $45000 - 25000 = 20000$

Similarly, for others states too,

States	Total students enrolled	Total rejected students	Appeared students	Non-appeared students
J&K	50000	5000	25000	20000
MP	60000	18000	30000	12000
UP	48000	12000	27000	9000
HP	32000	8000	16000	8000
UK	20000	3000	10000	7000

Total enrolled students= $\frac{75}{100} \times 48000 = 36000$

Total appeared students= $\frac{150}{100} \times 20000 = 30000$

Required number= $36000 - 30000 = 6000$

S53. Ans.(c)

Sol.

For J&K, Total enrolled students= 50000

Total rejected students= $50000 \times \frac{10}{100} = 5000$

Total appeared students= $(50000 - 5000) \times \frac{5}{9} = 25000$

Total non-appeared students= $45000 - 25000 = 20000$

Similarly, for others states too,

States	Total students enrolled	Total rejected students	Appeared students	Non-appeared students
J&K	50000	5000	25000	20000
MP	60000	18000	30000	12000
UP	48000	12000	27000	9000
HP	32000	8000	16000	8000
UK	20000	3000	10000	7000

Required ratio=30000:5000 =6: 1

S54. Ans.(e)

Sol.

For J&K, Total enrolled students= 50000

Total rejected students= $50000 \times \frac{10}{100} = 5000$

Total appeared students= $(50000 - 5000) \times \frac{5}{9} = 25000$

Total non-appeared students= $45000 - 25000 = 20000$

Similarly, for others states too,

States	Total students enrolled	Total rejected students	Appeared students	Non-appeared students
J&K	50000	5000	25000	20000
MP	60000	18000	30000	12000
UP	48000	12000	27000	9000
HP	32000	8000	16000	8000
UK	20000	3000	10000	7000

$$\text{Required percent} = \frac{30000-8000}{8000} \times 100 = 275\%$$

S55. Ans.(e)

Sol.

For J&K, Total enrolled students= 50000

Total rejected students= $50000 \times \frac{10}{100} = 5000$

Total appeared students= $(50000 - 5000) \times \frac{5}{9} = 25000$

Total non-appeared students= $45000 - 25000 = 20000$

Similarly, for others states too,

States	Total students enrolled	Total rejected students	Appeared students	Non-appeared students
J&K	50000	5000	25000	20000
MP	60000	18000	30000	12000
UP	48000	12000	27000	9000
HP	32000	8000	16000	8000
UK	20000	3000	10000	7000

$$\text{Required sum} = 30000+27000+16000=73000$$

S56. Ans.(c)

Sol.

$$\text{Total cars sold by F in 2018} = \frac{125}{100} \times 60,000 \times \frac{80}{100} = 60,000$$

$$\text{So, total cars manufactured by F in 2018} = 60,000 \times \frac{100}{80} = 75,000$$

$$\text{Required difference} = 80,000 - 75,000 = 5,000$$

S57. Ans.(a)

Sol.

$$\begin{aligned} \text{Total unsold cars of A, C \& E together in 2018} &= \left(60,000 \times \frac{100-80}{100}\right) + \left(50,000 \times \frac{100-90}{100}\right) + \\ &\left(40,000 \times \frac{100-75}{100}\right) \\ &= 12,000 + 5,000 + 10,000 \\ &= 27,000 \end{aligned}$$

$$\begin{aligned} \text{Required average} &= \frac{27,000}{3} \\ &= 9,000 \end{aligned}$$

S58. Ans.(e)

Sol.

$$\text{Sedan cars manufactured by C in 2018} = 50,000 \times \frac{14}{25} = 28,000$$

$$\text{Now, sedan cars sold by C in 2018} = 50,000 \times \frac{90}{100} \times \frac{125}{225} = 25,000$$

$$\text{So, unsold sedan cars of C in 2018} = 28,000 - 25,000 = 3,000$$

$$\text{And, unsold cars of A in 2018} = 60,000 \times \frac{100-80}{100} = 12,000$$

$$\text{Required \%} = \frac{3,000}{12,000} \times 100 = 25\%$$

S59. Ans.(d)

Sol.

$$\begin{aligned} \text{Total cars sold by A \& B together in 2018} &= \left(60,000 \times \frac{80}{100}\right) + \left(80,000 \times \frac{85}{100}\right) \\ &= 48,000 + 68,000 = 1,16,000 \end{aligned}$$

$$\begin{aligned} \text{Total cars sold by C \& D together in 2018} &= \left(50,000 \times \frac{90}{100}\right) + \left(75,000 \times \frac{60}{100}\right) \\ &= 45,000 + 45,000 = 90,000 \end{aligned}$$

$$\text{Required percentage} = \frac{1,16,000-90,000}{90,000} \times 100 = 28\frac{8}{9}\%$$

S60. Ans.(b)

Sol.

$$\text{Total cars manufactured by E in 2019} = \frac{150}{100} \times 40,000 = 60,000$$

$$\text{Now, total unsold cars of E in 2019} = \left(40,000 \times \frac{100-75}{100}\right) - 4,000 = 6,000$$

$$\text{So, cars sold by E in 2019} = 60,000 - 6,000 = 54,000$$

$$\text{And, cars sold by C in 2018} = \left(50,000 \times \frac{90}{100}\right) = 45,000$$

$$\text{Required difference} = 54,000 - 45,000 = 9,000$$

S61. Ans.(c)

Sol. The correct answer is (c) " To create a more just and equitable society by advancing impartiality and parity."

According to the passage, the philosophy of education recognizes the societal structure and its principles and aims to align educational goals with them. One of the goals is to promote fairness and equality in society through educational practices and principles. This includes advancing impartiality and parity, ensuring that education fosters a more just and equitable society.

Option (a) To establish proficient members of the community who can contribute effectively: This option does not directly address the goal of promoting fairness and equality through educational practices and principles. It focuses more on developing competent individuals for the community, but it does not specifically mention the promotion of fairness and equality. Therefore, this option is incorrect.

Option (b) To emphasize the importance of personal accomplishment rather than collaborative advancement: This option contradicts the goal mentioned in the question. The goal of the philosophy of education, as stated in the passage, is to promote fairness and equality. It recognizes the importance of both personal accomplishment and collaborative progress in the context of societal values. This option incorrectly suggests a focus solely on personal accomplishment, making it incorrect.

Option (d) To prioritize individual achievement over collaborative progress: This option goes against the goal mentioned in the question and the passage. The passage emphasizes the importance of both personal achievement and collaborative progress, rather than prioritizing one over the other. Therefore, this option is incorrect.

S62. Ans.(a)

Sol. The correct answer is (a), as a facilitator of knowledge and learning processes as it accurately describes the role of an educator in the philosophy of education. Educators are responsible for facilitating the acquisition of knowledge and supporting the learning processes of students.

Option (b) As an enforcer of rules and discipline: This option is incorrect as it does not capture the primary role of an educator in the philosophy of education. While educators may have a role in maintaining discipline and creating a conducive learning environment, their main focus is on facilitating learning rather than enforcing rules.

Option (c) As a passive observer of students' progress: This option is incorrect as it portrays educators as passive observers, which is not reflective of their active involvement in the educational process. Educators actively engage with students, guide their learning, and assess their progress.

Option (d) As a provider of grades and evaluations: This option is incorrect as it focuses solely on the evaluative aspect of an educator's role. While educators do provide grades and evaluations, their role goes beyond assessment to include guiding and supporting students' learning and growth.

Option (e) As a promoter of standardized testing: This option is incorrect as it narrows down the educator's role to promoting standardized testing, which is just one aspect of assessment in education. Educators have a broader responsibility to support students' learning and development through various instructional strategies and assessments.

S63. Ans.(a)

Sol. The **correct option is (a)**, By shaping educational policies and practices to meet the evolving needs of society. This option is correct because the philosophy of education aims to adapt and align educational systems with the changing needs of society. It recognizes the importance of keeping pace with societal advancements and preparing learners for the challenges of the future.

Option (b) By discouraging critical thinking and creativity in learners, hindering their ability to adapt to future challenges. This option is incorrect because the philosophy of education actually emphasizes the fostering of critical thinking and creativity in learners. It recognizes these skills as essential for adapting to and addressing future challenges effectively.

Option (c) By promoting standardized testing as the sole measure of educational success, neglecting other important aspects of learning. This option is incorrect because the philosophy of education advocates for a holistic approach to assessment and acknowledges that standardized testing alone is not sufficient to measure educational success. It values multiple forms of evaluation that consider diverse aspects of learning.

Option (d) By advocating for a one-size-fits-all approach to education, disregarding individual differences and diverse learning styles. This option is incorrect because the philosophy of education values and acknowledges the importance of individual differences and diverse learning styles. It encourages personalized and inclusive approaches to education that cater to the unique needs and strengths of learners.

Option (e) By prioritizing rote memorization over conceptual understanding and application of knowledge. This option is incorrect because the philosophy of education recognizes the significance of conceptual understanding and application of knowledge. It encourages active learning, critical thinking, and practical application of knowledge, rather than relying solely on rote memorization.

S64. Ans.(a)

Sol. The **correct answer is (a)** A set of principles guiding educational practice. The philosophy of education is the study of the nature, purpose, and methods of education, and it involves examining the principles and values that guide educational practices, as well as the social, cultural, and historical contexts in which education occurs. It is concerned with the question of what it means to be an educated person and how we can foster that development in others.

Option(b) The physical arrangement of a classroom - This option is incorrect as the physical arrangement of a classroom is a component of educational practice, but not the philosophy of education itself.

Option(c) The study of the history of education - This option is incorrect as the study of the history of education is an important aspect of the philosophy of education, but it is not the only focus.

Option(d) A type of teaching method - This option is incorrect as the philosophy of education is not a specific teaching method, but rather a set of guiding principles that inform educational practices.

S65. Ans.(c)

Sol. The correct answer is **(c) comprehend**.

In the passage, the word "understand" is used to describe the aim of the philosophy of education, which is to comprehend the nature, purpose, and methods of education. "Comprehend" has a similar meaning to "understand," as it refers to the ability to grasp or understand something fully.

-
- (a) **penetrate** - to pierce, pass into, or force a way through
 - (b) **misinterpret** - to understand wrongly or mistakenly
 - (c) **comprehend** - to understand the meaning or significance of something
 - (d) **misconstrue** - to interpret wrongly or misunderstand
 - (e) **irresistible** - impossible to resist or refuse

S66. Ans.(e)

Sol. The most opposite word in definition to the highlighted word "enterprise" will be (e) inertia. "Enterprise" in this context refers to an active, purposeful endeavour or undertaking, while "inertia" refers to a lack of movement or action.

- (a) **Gamble:** This word has a connotation of risk-taking, which is not opposite to the idea of enterprise.
- (b) **Company:** While "company" is not an exact synonym of "enterprise," the two words are often used interchangeably and therefore not opposite in meaning.
- (c) **Firm:** Like "company," this word is not opposite in meaning to "enterprise."
- (d) **Ambition:** While "ambition" can be seen as a synonym for "enterprise" in some contexts, it is not opposite in meaning.
- (e) **Inertia:** This word refers to a lack of motion or activity, which is the opposite of the dynamic, active connotations of "enterprise."

S67. Ans.(a)

Sol. The word "**dynamic**" is the appropriate choice to fill the blank as it indicates a process that is constantly changing and evolving. This aligns with the notion that the philosophy of education is an ongoing conversation that involves various stakeholders.

The words "frail," "effete," "impotent," and "feeble" are all incorrect choices to fill the blank as they all indicate weakness or lack of strength. These words do not align with the idea that the philosophy of education is a dynamic and ongoing conversation.

- (a) **Dynamic:** characterized by constant change, activity, or progress
- (b) **Frail:** weak and delicate
- (c) **Effete:** no longer capable of effective action, weak or ineffective
- (d) **Impotent:** lacking power or ability, unable to take effective action
- (e) **Feeble:** lacking physical strength, weak and frail.

S68. Ans.(c)

Sol. For justification of the answer, refer to the lines "**From the perspective of physics, time is a relative measure of the motion of objects, and it is defined by the interval between two events,**" in the first paragraph of the passage. These lines justify option (c) as the correct answer. None of the other options can answer the question appropriately.

S69. Ans.(b)

Sol. For justification of the answer, refer to the first line in the second paragraph which states that the **“perception of time by humans ... can vary based on several factors, including age, mood, and cultural background. For example, a person who is bored may feel that time is passing more slowly than someone who is engaged in an activity that they enjoy.”** Only option (b) gives the factors mentioned in the passage on which the perception of time is based. Option (a) is wrong as the perception of time is not based on political systems, but instead, political systems are based on the perception of time. Options (c) and (d) are not mentioned in the passage as being factors for the perception of time by humans. Therefore, the correct answer is option (b).

S70. Ans.(a)

Sol. The passage states in the beginning of the third paragraph that **“The measurement of time has allowed humans to organize their lives and create a sense of order in the world. Time is used to regulate social behaviour, and it is also a critical factor in economic and political systems.”** Therefore, the correct answer is (a). Options (b) and (e) are irrelevant as answers to the question, with (d) being somewhat incorrect according to the context of the passage. Options (c) and (d) are incorrect with respect to the information in the passage.

S71. Ans.(c)

Sol. The passage explains that time is an essential aspect of human culture. The justification for the answer can be found in the third paragraph which states that, **“The cultural significance of time is evident in the vast number of idioms and expressions that refer to time in different languages, such as “time is money” or “time flies when you're having fun.”** Therefore, the correct answer is (c). Options (b) and (e) are irrelevant as answers to the question, with (d) being somewhat incorrect according to the context of the passage. Options (a) and (d) are incorrect with respect to the information in the passage.

S72. Ans.(b)

Sol. The word “emphasis” refers to the act of giving importance or prominence to something. The most appropriate antonym of this word would be “disregard,” which means to ignore or pay no attention to something.

Option (a) “enhancement” means to improve or increase something, which is not an antonym of “emphasis.”

Option (c) “endeavour” means to make an effort to achieve something, which is not an antonym of “emphasis.”

Option (d) “sequence” refers to the order in which things occur and is not an antonym of “emphasis.”

Option (e) “constriction” means to restrict or limit something, which is not an antonym of “emphasis.”

S73. Ans.(a)

Sol. Among the given options, only C-D and B-E can be joined to form grammatically and contextually correct sentences. The sentences thus formed would be:

(I) Experts are of the opinion that the government needs to implement immediate measures

(II) As per recent reports, the economy is showing signs of a fast recovery.

S74. Ans.(d)

Sol. Among the given options, only B-E and A-D can be joined to form grammatically and contextually correct sentences. The sentences thus formed would be

- (I) The minister of agriculture has announced a new policy to determine minimum support price.
- (II) The police have recently launched a massive campaign to curb and prevent cybercrime.

S75. Ans.(b)

Sol. Among the given options, only C-D can be joined to form grammatically and contextually correct sentence. The sentence thus formed would be:

- (I) Despite several rounds of negotiations, the two countries failed to reach a resolution on the trade dispute.

S76. Ans.(c)

Sol. Among the given options, only A-F can be joined to form grammatically and contextually correct sentence. The sentence thus formed would be:

- (I) Although he had no prior experience in the field, he managed to turn the company around in just a year.

S77. Ans.(d)

Sol. Among the given options, only C-F can be joined to form grammatically and contextually correct sentence. The sentence thus formed would be:

- (I) The policy makers' decision to hike taxes has drawn criticism from several quarters.

S78. Ans.(c)

Sol. The pair that needs to be interchanged to make the sentence contextually correct is D-C. The resultant sentence comes out to be, "The idea of mindfulness has become increasingly **popular** among people **seeking** to **reduce** stress and **improve** their well-being." The original sentence is contextually invalid and no other option gives a valid interchange for the highlighted words to make the sentence correct.

S79. Ans.(d)

Sol. The pair that needs to be interchanged to make the sentence contextually correct is D-C. The resultant sentence comes out to be, "The team's **efforts** in the championship were ultimately **unsuccessful** as they lost the **final** game to their **opponents**." The original sentence is contextually invalid and no other option gives a valid interchange for the highlighted words to make the sentence correct.

S80. Ans.(b)

Sol. The pair that needs to be interchanged to make the sentence contextually correct is (b) A-D and B-C. The resultant sentence comes out to be, "She had to **choose** between **going** to the party or **helping** out her parents, but she ultimately **decided** on the former." The original sentence is contextually invalid and no other option gives a valid interchange for the highlighted words to make the sentence correct.

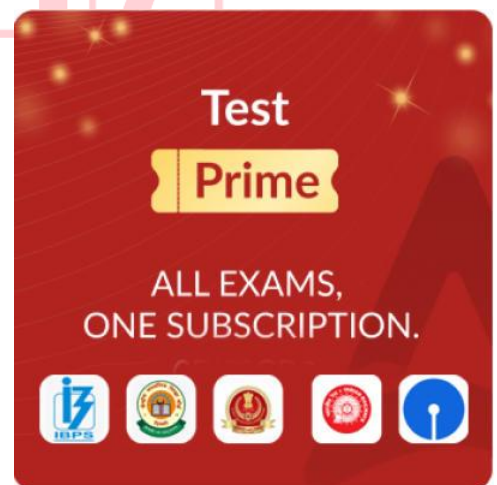

Test
Prime

ALL EXAMS,
ONE SUBSCRIPTION.



S81. Ans.(c)

Sol. The given sentence will become grammatically and contextually correct if (A) and (D) are interchanged. Therefore, option (c) is the most suitable answer choice.

S82. Ans.(d)

Sol. The given sentence will become grammatically and contextually correct if (A) and (D) and (B) and (A) are interchanged. Therefore, option (d) is the most suitable answer choice.

S83. Ans.(d)

Sol. The word "consistent" means compatible or in agreement with something. It has been used correctly in statement (iii) and (ii). In statement (i), it should be replaced with "dominant".

S84. Ans.(c)

Sol. The word "vulnerable" means exposed to the possibility of being attacked or harmed, either physically or emotionally. It has been used correctly in statements (i) and (ii) only. While in statement (iii), it should be replaced with the word "profitable" which means beneficial; useful.

S85. Ans.(c)

Sol. The word "prominent" means very well-known and important. It has been used correctly in statements (i) and (iii) only. While in statement (ii), "prominent" should be replaced with "expense" which means the cost incurred in or required for something.

S86. Ans.(e)

Sol. The phrase "**run out of**" means to use up or exhaust a supply of something, or to leave a place quickly. (A) "We need to go to the store because we've run out of milk." In this sentence, "run out of" means that the supply of milk has been exhausted and more is needed.

(B) "During the power outage, we ran out of candles and had to use a flashlight instead." This sentence correctly uses "run out of" to indicate that the supply of candles was completely used up.

(C) "The marathon runner ran out of energy and couldn't finish the race." In this sentence, "run out of" means to use up or exhaust a supply of energy, in this case, the runner becoming too tired to continue the race.

All of the above sentences, use "run out of" to convey the idea of using up or exhausting a supply of something or leaving a place quickly.

S87. Ans.(b)

Sol. The phrase "**come up with**" means to produce or create something, to think of or suggest something, or to happen or occur.

(A) "Can you come up with a better solution?" In this sentence, "come up with" is used correctly to ask someone to suggest a better solution.

(B) "We came up with the beach yesterday, and it was so hot". Here, the use of phrase is incorrect because "come up with" means to think of or suggest something, and it doesn't make sense in the context of going to a beach.

(C) "She came up with a brilliant idea for the project". In this sentence, "come up with" is used correctly to describe a person who thinks of a brilliant idea for a project.

S88. Ans.(c)

Sol. Part (C) of the given sentence contains an error. The adjective "incessant" is an incorrect form to modify the verb "ringing". A better adjective that could have been used is "incessantly", which is the adverbial form. So the correct sentence should be: "The sound of the alarm clock ringing incessantly was driving her crazy." "Incessantly" means without interruption or constantly. It refers to an action that continues without stopping or pausing.

S89. Ans.(c)

Sol. The use of the verb "have" in the given sentence is incorrect. It is not the most appropriate verb to use in this context. The verb "have" suggests that the soldiers possess or own something, which is not the intended meaning in this sentence. A better verb to use in this context would be "are" instead of "have". The corrected sentence would be: "A militia is a group of non-professional soldiers who are typically composed of citizens."

S90. Ans.(d)

Sol. The error is in part (D) of the given sentence. The correct form of the verb is "entrenched" and not "entrench". Therefore, the correct sentence is: "The cultural and social norms of a society can become deeply entrenched over time." The corrected sentence means that the cultural and social norms can become firmly established and difficult to change over time.

S91. Ans.(e)

Sol. There is no grammatical error in the given sentence. It is a correct and meaningful sentence. The preposition "in" is correctly used to indicate that the civilians were trapped within the geographical boundaries of the conflict zone.

S92. Ans.(b)

Sol. The error is in part (B) of the sentence: "the act of hold" should be corrected to "the act of holding". The verb form should be in the gerund form, which functions as a noun in the sentence. The corrected sentence would be: "Detention refers to the act of holding someone in custody as a form of punishment."

S93. Ans.(e)

Sol. The word "**nevertheless**" is used to connect two clauses that contrast with each other. In this case, the first clause states that the people had conflicting opinions and viewpoints, while the second clause states that they found common ground and reached a compromise. The word "nevertheless" shows that the people were able to find common ground and reach a compromise even though they had conflicting opinions and viewpoints.

The sentence formed is "They had conflicting opinions and viewpoints but nevertheless found common ground and reached a compromise"

The other options are not correct because they do not properly connect the two clauses.

S94. Ans.(c)

Sol. The word “**eventually**” is a conjunction that means "in the end" or "finally". It is used to connect two clauses that are related in time, and it indicates that the second clause happened after the first. In this case, the first clause is "They started off as strangers but", and the second clause is “became close friends”. The word "eventually" connects these two clauses and indicates that the friendship developed over time. The sentence formed is “They started off as strangers, but through shared experiences and conversations they eventually became close friends”

The other answer choices are not correct as none of them can be used to connect the two sentences grammatically and contextually.

S95. Ans.(a)

Sol. The word “**notably**” is used to introduce something that is particularly important or significant. In this case, the lead actor's performance was one of the things that was praised about the play.

The other options are not as good because they do not introduce something that is particularly important or significant. The sentence formed is “The play was highly praised for the inspired performance of the cast, notably the lead actor's compelling portrayal.”

S96. Ans.(c)

Sol. The most appropriate option to fill in the blank would be “diligence”.

The word "diligence" means careful and persistent effort, which fits the context of the sentence. The sentence describes the new employee's behaviour as enthusiastic and eager to learn, indicating that he was putting in a lot of effort and attention into his work. The use of the word "diligence" suggests that he was also being careful and thorough in his work, which is a positive attribute in an employee.

The other options do not fit the context of the sentence as well. "Reluctance" means unwillingness to do something, which is the opposite of what the sentence is describing. "Indifference" means a lack of interest or concern, which also does not fit the context. "Scepticism" means doubt or mistrust, which is not relevant to the sentence. "Frivolity" means lack of seriousness or sense, which is also not relevant to the sentence.

S97. Ans.(e)

Sol. The most appropriate option to fill in the blank would be “captivating”.

The word "captivating" means capable of attracting and holding attention, which fits the context of the sentence. The sentence describes the novel's plot and characters as intricate and richly drawn, indicating that they were well-developed and interesting. The use of the word "captivating" suggests that the novel was able to hold the attention of readers who enjoy literary fiction.

The other options do not fit the context of the sentence as well. "Tedious" means boring and tiresome, which is the opposite of what the sentence is describing. "Banal" means unoriginal and lacking in novelty, which is not relevant to the sentence. "Insidious" means lacking flavour or interest, which is the opposite of what the sentence is describing. "Trite" means overused and lacking in freshness, which also does not fit the context.

S98. Ans.(c)

Sol. The correct phrase is "efficient time management skills." This means that the team was able to complete the project ahead of schedule because of their ability to manage time efficiently. "Efficient time managed skills" and option (a) are incorrect because "manage" should be in its infinitive form, "management." Option (b) is incorrect because "efficiency" should be in its adjectival form, "efficient." Option (d) is incorrect because "timed" is unnecessary and does not accurately describe the team's management skills.

S99. Ans.(b)

Sol. The correct phrase is "by a desire to" This means that the board's decision to increase the advertising budget was influenced by a desire to attract new customers. The original sentence mistakenly uses the preposition "of" instead of "by," which changes the meaning of the sentence and makes it sound awkward and unclear. Option (a) is incorrect because "with" is not the appropriate preposition to express influence or motivation. Option (c) is incorrect because "for" is not the appropriate preposition to express influence or motivation. Option (d) is incorrect because "to" is not the appropriate preposition to express influence or motivation.

S100. Ans.(e)

Sol. The correct phrase is "to communicate clearly." This means that the manager's failure to communicate clearly led to misunderstandings. The error in the sentence is the use of the word "clarity." Clarity is a noun that refers to the quality of being clear, transparent, or easy to understand. However, in the context of the sentence, the intended meaning is the manager's failure to communicate clearly, which is an adverb that describes the way in which the manager communicated. Option (a) is incorrect because "with clarity" is not the most commonly used phrase to describe clear communication. Option (b) is incorrect because "in clarity" suggests that communication was the result of clarity rather than the other way around. Option (c) is incorrect because "clearness" is not commonly used to describe clear communication. Option (d) is incorrect because "clearness" is not commonly used to describe clear communication.

S101. Ans.(a)

Sol.

$$\frac{32}{100} \times 750 + ?^2 = \frac{48}{100} \times 1700$$

$$240 + ?^2 = 816$$

$$?^2 = 576$$

$$? = 24$$

S102. Ans.(c)

Sol.

$$\frac{1152}{?} + \frac{24}{100} \times 450 = 12 \times 13$$

$$\frac{1152}{?} = 156 - 108$$

$$? = \frac{1152}{48}$$

$$? = 24$$

S103. Ans.(a)

Sol.

$$?^3 \times \left(\frac{80}{100} \times 40 + 8 \right) = \frac{80}{100} \times 10800$$

$$?^3 \times 40 = 8640$$

$$?^3 = 216$$

$$? = 6$$

S104. Ans.(e)

Sol.

$$1268 + 1728 - ? = 1000$$

$$? = 2996 - 1000$$

$$? = 1996$$

S105. Ans.(b)

Sol.

$$? \times \left(\frac{56}{100} \times 550 + 112 \right) = \frac{70}{100} \times 3000$$

$$? \times (308 + 112) = 2100$$

$$? = \frac{2100}{420}$$

$$? = 5$$

S106. Ans.(c)

Sol.

$$\text{Amount paid by Vikas to Shivam} = \left(X \times \frac{20}{100} \times 2 \right) = \text{Rs. } (0.4X)$$

$$\text{Now, amount paid by Harish to Vikas} = \left(X \times \frac{80}{100} \times \frac{25}{100} \times 2 \right) = \text{Rs. } (0.4X)$$

$$\text{And, interest received by Vikas from the scheme} = \left(X \times \frac{20}{100} \times \frac{30}{100} \times 2 \right) = \text{Rs. } (0.12X)$$

ATQ,

$$(0.12X + 0.4X) - 0.4X = 6,000$$

$$X = 50,000$$

S107. Ans.(a)

Sol.

ATQ,

$$\frac{\left(\left(100 \times \frac{3}{5} \right) + \left(T \times \frac{7}{12} \right) \right)}{\left(\left(100 \times \frac{2}{5} \right) + \left(T \times \frac{5}{12} \right) \right)} = \frac{33}{23}$$

$$\frac{60 + \frac{7}{12}T}{40 + \frac{5}{12}T} = \frac{33}{23}$$

$$T = 180$$

S108. Ans.(a)

Sol.

Let total capacity of tank be 225 units (LCM of 45 & 75)

So, efficiency of pipes A, B & C together = $\frac{225}{45} = 5$ units/minute

And, efficiency of pipes B & C together = $\frac{225}{75} = 3$ units/minute

So, efficiency of pipe A = $5 - 3 = 2$ units/minute

Now, efficiency of pipe B = $3 \times \frac{200}{300} = 2$ units/minute

So, required time = $\frac{225}{2+2} = 56.25$ minutes

S109. Ans.(b)

Sol. Let cost price of a pen & a pencil be Rs.30x & Rs.40x respectively.

So, marked price of a pen = Rs. 36x

And, marked price of a pencil = Rs.48x

Now, selling price of a pen = Rs. 32.4x

And, selling price of a pencil = Rs. 43.2x

ATQ,

$$(43.2x + 32.4x) - (30x + 40x) = 2.8$$

$$x = 0.5$$

So, cost price of a pen = Rs.15

S110. Ans.(d)

Sol.

Let present age of C be x years.

So, present age of A = $(x + 16)$ years

And, present age of B = $\frac{75}{100} \times (x + 16 + 4)$

$$= \frac{3}{4} \times (x + 20) \text{ years}$$

ATQ,

$$\frac{\left(\frac{3}{4} \times (x+20)\right) + 5}{x+5} = \frac{7}{5}$$

$$x = 20$$

Hence, present age of A = 36 years

And, present age of B = 30 years

And, present age of C = 20 years

$$\text{Required \%} = \frac{36}{30+20} \times 100$$

$$= 72\%$$

S111. Ans.(b)**Sol.**

I. $18x^2 + 33x + 14 = 0$

$18x^2 + 21x + 12x + 14 = 0$

$3x(6x + 7) + 2(6x + 7) = 0$

$(6x + 7)(3x + 2) = 0$

$x = -\frac{7}{6} \text{ or } -\frac{2}{3}$

II. $8y^2 + 22y + 15 = 0$

$8y^2 + 10y + 12y + 15 = 0$

$2y(4y + 5) + 3(4y + 5) = 0$

$(4y + 5)(2y + 3) = 0$

$y = -\frac{5}{4}, -\frac{3}{2}$

So, $x > y$.

S112. Ans.(e)**Sol.**

I. $x^2 - 12x + 32 = 0$

$x^2 - 4x - 8x + 32 = 0$

$x(x - 4) - 8(x - 4) = 0$

$(x - 4)(x - 8) = 0$

$x = 4, 8$

II. $y^2 - 15y + 54 = 0$

$y^2 - 6y - 9y + 54 = 0$

$y(y - 6) - 9(y - 6) = 0$

$(y - 6)(y - 9) = 0$

$y = 6, 9$

So, no relation.

S113. Ans.(d)**Sol.**

I. $7x^2 + 27x + 18 = 0$

$7x^2 + 21x + 6x + 18 = 0$

$7x(x + 3) + 6(x + 3) = 0$

$(x + 3)(7x + 6) = 0$

$x = -3, -\frac{6}{7}$

II. $2y^2 + 13y + 21 = 0$

$2y^2 + 6y + 7y + 21 = 0$

$2y(y + 3) + 7(y + 3) = 0$

$(y + 3)(2y + 7) = 0$

$y = -3, -\frac{7}{2}$

So, $x \geq y$.

S114. Ans.(b)

Sol.

I. $6x - 8y = 7$ _____(i)

II. $4x + 3y = 38$ _____(ii)

On solving (i) & (ii):

$y = 4, x = 6.5$

So, $x > y$.

S115. Ans.(e)

Sol.

I. $40x^2 - 81x + 35 = 0$

$40x^2 - 25x - 56x + 35 = 0$

$5x(8x - 5) - 7(8x - 5) = 0$

$(8x - 5)(5x - 7) = 0$

$x = \frac{5}{8}, \frac{7}{5}$

II. $2y^2 - 7y + 3 = 0$

$2y^2 - y - 6y + 3 = 0$

$y(2y - 1) - 3(2y - 1) = 0$

$(2y - 1)(y - 3) = 0$

$y = \frac{1}{2}, 3$

So, no relation.

S116. Ans.(b)

Sol.

Let A, B, C's investment be $3x, 4x$ and $5x$ respectively

ATQ,

A - $\frac{3x \times 3 + \frac{9x}{4} \times 9}{4}$

B - $\frac{4x \times 12}{4}$

C - $5x \times 12$

= 117: 192: 240

Let profit share of A, B and C be $117y, 192y$ and $240y$

$117y = 702$

$y = 6$

Required difference = $48y = \text{Rs } 288$

S117. Ans.(a)

Sol.

Let radius & height of each cylindrical vessel be ' r cm' & ' h cm' respectively.

So, radius of spherical ball = $3r$ cm

ATQ,

$$r - h = 3$$

$$r = 3 + h \quad \dots(i)$$

And,

Volume of spherical ball = 63 × volume of cylindrical vessel

$$\frac{4}{3}\pi(3r)^3 = 63 \times \pi \times r^2 \times h$$

$$\Rightarrow 4r = 7h \quad \dots(ii)$$

On solving (i) & (ii), we get:

$$h = 4, r = 7$$

So, required radius = 3r

$$= 21 \text{ cm}$$

S118. Ans.(a)

Sol.

Total distance covered by Vikash = 9+1=10 km.

Time taken by Vikash = 10×6

=60 min

So, time taken by Mohit = 60-4=56 min

Distance covered by Mohit = 9-1

=8 km

$$\text{Speed of Mohit} = \frac{8}{56}$$

$$= \frac{1}{7} \text{ km/min.}$$

S119. Ans.(c)

Sol.

Let speed of current be C km/hr

So, speed of Boat in still water = 5C km/hr

After technical problem, speed of Boat (in still water) = $5C \times \frac{4}{5} = 4C$

ATQ

$$\Rightarrow \frac{16}{5C+C} + \frac{40}{4C+C} = \frac{56}{\frac{7}{20} \times 60}$$

$$\Rightarrow \frac{16}{6C} + \frac{40}{5C} = \frac{56}{21}$$

$$\Rightarrow C = 4 \text{ km/hr.}$$

S120. Ans.(e)

Sol. Let the length and speed of train – A be x meters and y m/sec respectively.

ATQ,

$$\frac{l}{16} = y$$

$$l = 16y \text{ ---- (i)}$$

Now,

$$\frac{l+200}{24} = y \quad \dots(ii)$$

from (i) and (ii) we get -

$$y = 25 \text{ \& } l = 400$$

$$\text{Speed of train - B} = 108 \times \frac{5}{18} = 30 \text{ m/sec}$$

$$\text{Required time} = \frac{400+480}{25+30} = 16 \text{ seconds}$$

S121. Ans.(e)

Sol. From I -

Let radius of circle be 'r' and length of rectangle be 'l'

$$2r + 2l = 76$$

$$r + l = 38 \text{ ----- (i)}$$

From II -

Let radius of circle be 'r' and length and breadth of rectangle be 'l' & 'b' respectively

$$2(l + b) + r = 94 \text{ ----- (ii)}$$

So, we can't determine value of r, l and b

So, both statements together are not sufficient

S122. Ans.(a)

Sol.

From I & II -

Total of present age of B & C = 96 years

Let present age of D be t years

Present age of C = (t + 8) years

Present age of A = 2t years

then, present age of B = 3t years

ATQ,

$$\frac{3t+t+8}{2} = 48 \text{ years}$$

$$4t + 8 = 96$$

$$t = 22 \text{ years}$$

age of A two years later = $2 \times 22 + 2 = 46$ years

Can be answered from I & II together



S123. Ans.(e)

Sol.

$$\text{Speed of train A} = 72 \times \frac{5}{18} = 20 \text{ m/sec}$$

Let length of train A be L m

From I

$$\text{Speed of train B} = 20 \times \frac{150}{100} = 30 \text{ m/sec}$$

From II

length of train B = 0.5 L m

From I & II

$$\frac{L + 0.5L}{12} = 30 + 20$$

$$1.5L = 600 \text{ m}$$

$$L = 400 \text{ meters}$$

So, Both I and II together sufficient

S124. Ans.(a)

Sol.

Total fruits in basket = 12

Given, number of apples = 5

So, let total number of oranges = n

So, number of pears = (7 - n)

From I -

$$\frac{n}{12} + \frac{7-n}{12} = \frac{7}{12}$$

So, we can't determine value of n from statement I

From II -

$$\frac{n(n-1)}{12 \times 11} + \frac{(7-n)(6-n)}{12 \times 11} = \frac{1}{6}$$

$$2n^2 - 14n + 42 = 22$$

$$2n^2 - 14n + 20 = 0$$

$$2n^2 - 10n - 4n + 20 = 0$$

$$2n(n - 5) - 4(n - 5) = 0$$

$$n = 2, 5$$

From II alone we can determine the difference between oranges & pears in the basket. So, only statement II alone is sufficient to give answer of the question.

S125. Ans.(a)

Sol.

Form I -

Cost price (CP) of 20 dozen pens = 20 × 40 = Rs.800

So, statement I alone is not sufficient to answer the question.

Form II -

Let us assume that CP for pen is Rs. X per dozen.

Selling price (SP) of 8 dozen pens at 10 % profit = $X \times 8 \times \frac{110}{100}$ = Rs. 8.8X

Selling price (SP) of 12 dozen pens at 20 % profit = $X \times 12 \times \frac{120}{100}$ = Rs. 14.4X

$$\text{So \% profit} = \frac{\{(8.8X + 14.4X) - 20X\}}{20X} \times 100 = 16\%$$

Hence, statement II alone is sufficient.

S126. Ans.(b)

Sol.

Let units of P sold in 2018 be $100x$.

So, units of P sold in 2019 = $90x$

And, units of Q sold in 2018 = $50x$

Now, units of S sold in 2018 = $50x$

Now, units of R sold in 2018 = $70x$

And, units of T sold in 2018 = $70x - 2,000$

Now, units of Q sold in 2019 = $60x$

And, units of R sold in 2019 = $90x$

Now, units of S sold in 2019 = $100x$

And, units of T sold in 2019 = $70x$

ATQ,

$$\frac{70x - 2,000 + 70x}{2} = 50x$$

$$140x - 2,000 = 100x$$

$$x = 50$$

Products	2018	2019
P	5,000	4,500
Q	2,500	3,000
R	3,500	4,500
S	2,500	5,000
T	1,500	3,500

$$\text{Required \%} = \frac{3,500 + 2,500}{3,000} \times 100$$

$$= 200\%$$

S127. Ans.(a)

Sol.

Let units of P sold in 2018 be $100x$.

So, units of P sold in 2019 = $90x$

And, units of Q sold in 2018 = $50x$

Now, units of S sold in 2018 = $50x$

Now, units of R sold in 2018 = $70x$

And, units of T sold in 2018 = $70x - 2,000$

Now, units of Q sold in 2019 = $60x$

And, units of R sold in 2019 = $90x$

Now, units of S sold in 2019 = $100x$

And, units of T sold in 2019 = $70x$

ATQ,

$$\frac{70x - 2,000 + 70x}{2} = 50x$$

$$140x - 2,000 = 100x$$

$$x = 50$$

Products	2018	2019
P	5,000	4,500
Q	2,500	3,000
R	3,500	4,500
S	2,500	5,000
T	1,500	3,500

$$\text{Required average} = \frac{1}{3} \times (2,500 + 3,500 + 1,500)$$

$$= 2,500 \text{ units}$$

S128. Ans.(e)

Sol.

Let units of P sold in 2018 be $100x$.

So, units of P sold in 2019 = $90x$

And, units of Q sold in 2018 = $50x$

Now, units of S sold in 2018 = $50x$

Now, units of R sold in 2018 = $70x$

And, units of T sold in 2018 = $70x - 2,000$

Now, units of Q sold in 2019 = $60x$

And, units of R sold in 2019 = $90x$

Now, units of S sold in 2019 = $100x$

And, units of T sold in 2019 = $70x$

ATQ,

$$\frac{70x - 2,000 + 70x}{2} = 50x$$

$$140x - 2,000 = 100x$$

$$x = 50$$

Products	2018	2019
P	5,000	4,500
Q	2,500	3,000
R	3,500	4,500
S	2,500	5,000
T	1,500	3,500

$$\text{Required ratio} = \frac{2,500 + 1,500}{4,500 + 4,500}$$

$$= 4:9$$

S129. Ans.(d)

Sol.

Let units of P sold in 2018 be $100x$.

So, units of P sold in 2019 = $90x$

And, units of Q sold in 2018 = $50x$

Now, units of S sold in 2018 = $50x$

Now, units of R sold in 2018 = $70x$

And, units of T sold in 2018 = $70x - 2,000$

Now, units of Q sold in 2019 = $60x$
 And, units of R sold in 2019 = $90x$
 Now, units of S sold in 2019 = $100x$
 And, units of T sold in 2019 = $70x$
 ATQ,
 $\frac{70x - 2,000 + 70x}{2} = 50x$
 $140x - 2,000 = 100x$
 $x = 50$

Products	2018	2019
P	5,000	4,500
Q	2,500	3,000
R	3,500	4,500
S	2,500	5,000
T	1,500	3,500

Units sold of all these 5 products together in 2019 = $4,500 + 3,000 + 4,500 + 5,000 + 3,500$
 = 20,500 units

Units sold of all these 5 products together in 2018 = $5,000 + 2,500 + 3,500 + 2,500 + 1,500$
 = 15,000 units

$$\text{Required \%} = \frac{20,500 - 15,000}{15,000} \times 100$$

$$= 36\frac{2}{3}\%$$

S130. Ans.(d)

Sol.

Let units of P sold in 2018 be $100x$.
 So, units of P sold in 2019 = $90x$
 And, units of Q sold in 2018 = $50x$
 Now, units of S sold in 2018 = $50x$
 Now, units of R sold in 2018 = $70x$
 And, units of T sold in 2018 = $70x - 2,000$
 Now, units of Q sold in 2019 = $60x$
 And, units of R sold in 2019 = $90x$
 Now, units of S sold in 2019 = $100x$
 And, units of T sold in 2019 = $70x$
 ATQ,
 $\frac{70x - 2,000 + 70x}{2} = 50x$
 $140x - 2,000 = 100x$
 $x = 50$

Products	2018	2019
P	5,000	4,500
Q	2,500	3,000
R	3,500	4,500
S	2,500	5,000
T	1,500	3,500

Required profit = $(32-26) \times (5,000+4,500)$
 = Rs.57,000

S131. Ans.(b)

Sol. Wrong number = 2030

Pattern of series -

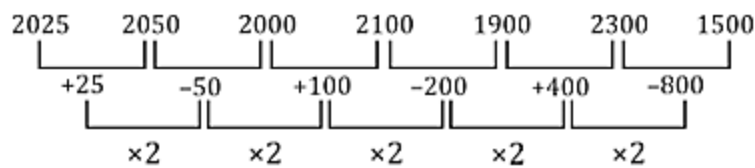

So, there should be 2025 in place of 2030.

S132. Ans.(d)

Sol. Wrong number = 10

Pattern of series -

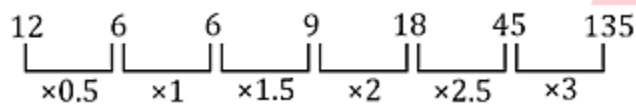

So, there should be 12 in place of 10.

S133. Ans.(a)

Sol. Wrong number = 318

Pattern of series -

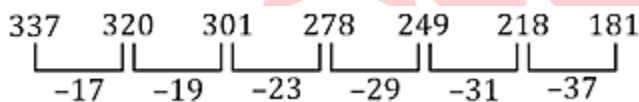

So, there should be 320 in place of 318.

S134. Ans.(d)

Sol. Wrong number = 820

Pattern of series -

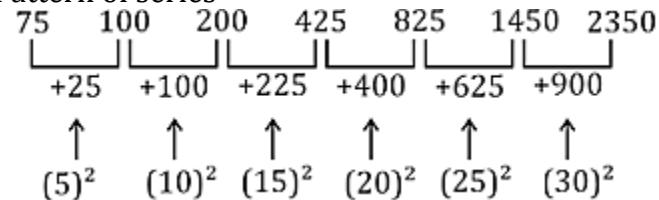

So, there should be 825 in place of 820.

S135. Ans.(b)

Sol. Wrong number = 285

Pattern of series -

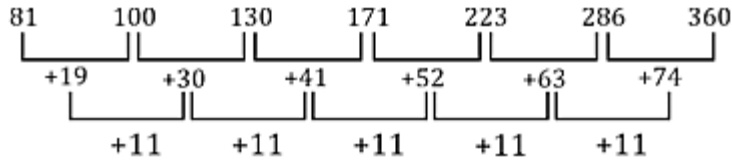

So, there should be 286 in place of 285.

S136. Ans.(a)

Sol.

In village A, male : female : transgender = 16 : 7 : 2

Total population of village A = 50000

$$\text{Male of A} = \frac{16}{25} \times 50,000 = 32,000$$

$$\text{Female of A} = \frac{7}{25} \times 50,000 = 14,000$$

$$\text{Transgender of A} = \frac{2}{25} \times 50,000 = 4,000$$

In village B,

female : transgender = 7 : 2.

Also male and female are equal in B.

Hence male : female : transgender = 7 : 7 : 2

$$\text{Male} = \frac{7}{16} \times 16,000 = 7,000$$

$$\text{Female} = \frac{7}{16} \times 16,000 = 7,000$$

$$\text{Transgender} = \frac{2}{16} \times 16,000 = 2,000$$

Similarly, in village C,

Male : Female : transgender = 9 : 7 : 5.5

$$= \boxed{18 : 14 : 11}$$

$$\text{Male} = \frac{18}{43} \times 43,000 = 18,000$$

$$\text{Female} = \frac{14}{43} \times 43,000 = 14,000$$

$$\text{Transgender} = \frac{11}{43} \times 43,000 = 11,000$$

Village	Male	Female	Transgender
A	32000	14000	4000
B	7000	7000	2000
C	18000	14000	11000

Female of A and B together = 14000 + 7000 = 21000



S137. Ans.(d)

Sol.

In village A, male : female : transgender = 16 : 7 : 2

Total population of village A = 50000

$$\text{Male of A} = \frac{16}{25} \times 50,000 = 32,000$$

$$\text{Female of A} = \frac{7}{25} \times 50,000 = 14000$$

$$\text{Transgender of A} = \frac{2}{25} \times 50000 = 4000$$

In village B,

female : transgender = 7 : 2.

Also male and female are equal in B.

Hence male : female : transgender = 7 : 7 : 2

$$\text{Male} = \frac{7}{16} \times 16000 = 7000$$

$$\text{Female} = \frac{7}{16} \times 16000 = 7000$$

$$\text{Transgender} = \frac{2}{16} \times 16000 = 2000$$

Similarly, in village C,

Male : Female : transgender = 9 : 7 : 5.5

$$= \boxed{18:14:11}$$

$$\text{Male} = \frac{18}{43} \times 43000 = 18000$$

$$\text{Female} = \frac{14}{43} \times 43000 = 14000$$

$$\text{Transgender} = \frac{11}{43} \times 43000 = 11000$$

Village	Male	Female	Transgender
A	32000	14000	4000
B	7000	7000	2000
C	18000	14000	11000

$$\text{Required Ratio} = \frac{14000}{14000} = 1 : 1$$

S138. Ans.(c)

Sol.

In village A, male : female : transgender = 16 : 7 : 2

Total population of village A = 50000

$$\text{Male of A} = \frac{16}{25} \times 50,000 = 32,000$$

$$\text{Female of A} = \frac{7}{25} \times 50,000 = 14000$$

$$\text{Transgender of A} = \frac{2}{25} \times 50000 = 4000$$

In village B,

$$\text{female : transgender} = 7 : 2.$$

Also male and female are equal in B.

$$\text{Hence male : female : transgender} = 7 : 7 : 2$$

$$\text{Male} = \frac{7}{16} \times 16000 = 7000$$

$$\text{Female} = \frac{7}{16} \times 16000 = 7000$$

$$\text{Transgender} = \frac{2}{16} \times 16000 = 2000$$

Similarly, in village C,

$$\text{Male : Female : transgender} = 9 : 7 : 5.5$$

$$= \boxed{18 : 14 : 11}$$

$$\text{Male} = \frac{18}{43} \times 43000 = 18000$$

$$\text{Female} = \frac{14}{43} \times 43000 = 14000$$

$$\text{Transgender} = \frac{11}{43} \times 43000 = 11000$$

Village	Male	Female	Transgender
A	32000	14000	4000
B	7000	7000	2000
C	18000	14000	11000

$$\text{Required average} = \frac{2000+11000}{2} = 6500$$

S139. Ans.(d)

Sol.

$$\text{In village A, male : female : transgender} = 16 : 7 : 2$$

$$\text{Total population of village A} = 50000$$

$$\text{Male of A} = \frac{16}{25} \times 50,000 = 32,000$$

$$\text{Female of A} = \frac{7}{25} \times 50,000 = 14000$$

$$\text{Transgender of A} = \frac{2}{25} \times 50000 = 4000$$

In village B,

$$\text{female : transgender} = 7 : 2.$$

Also male and female are equal in B.

$$\text{Hence male : female : transgender} = 7 : 7 : 2$$

$$\text{Male} = \frac{7}{16} \times 16000 = 7000$$

$$\text{Female} = \frac{7}{16} \times 16000 = 7000$$

$$\text{Transgender} = \frac{2}{16} \times 16000 = 2000$$

$$\text{Transgender} = \frac{2}{16} \times 16000 = 2000$$

Similarly, in village C,

$$\text{Male : Female : transgender} = 9 : 7 : 5.5$$

$$= \boxed{18:14:11}$$

$$\text{Male} = \frac{18}{43} \times 43000 = 18000$$

$$\text{Female} = \frac{14}{43} \times 43000 = 14000$$

$$\text{Transgender} = \frac{11}{43} \times 43000 = 11000$$

Village	Male	Female	Transgender
A	32000	14000	4000
B	7000	7000	2000
C	18000	14000	11000

$$\text{Required \%} = \frac{2000}{14000} \times 100 = 14\frac{2}{7}\%$$

S140. Ans.(c)

Sol.

In village A, male : female : transgender = 16 : 7 : 2

Total population of village A = 50000

$$\text{Male of A} = \frac{16}{25} \times 50,000 = 32,000$$

$$\text{Female of A} = \frac{7}{25} \times 50,000 = 14000$$

$$\text{Transgender of A} = \frac{2}{25} \times 50000 = 4000$$

In village B,

female : transgender = 7 : 2.

Also male and female are equal in B.

Hence male : female : transgender = 7 : 7 : 2

$$\text{Male} = \frac{7}{16} \times 16000 = 7000$$

$$\text{Female} = \frac{7}{16} \times 16000 = 7000$$

$$\text{Transgender} = \frac{2}{16} \times 16000 = 2000$$

Similarly, in village C,

Male : Female : transgender = 9 : 7 : 5.5

$$= \boxed{18:14:11}$$

$$\text{Male} = \frac{18}{43} \times 43000 = 18000$$

$$\text{Female} = \frac{14}{43} \times 43000 = 14000$$

$$\text{Transgender} = \frac{11}{43} \times 43000 = 11000$$



Village	Male	Female	Transgender
A	32000	14000	4000
B	7000	7000	2000
C	18000	14000	11000

$$\text{Required percentage} = \frac{7000}{14000} \times 100 = 50\%$$

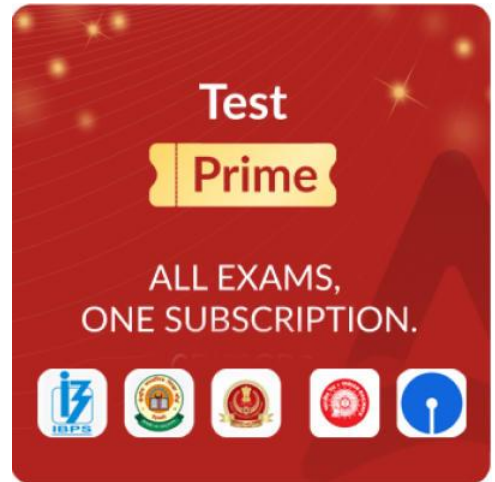

Test
Prime

ALL EXAMS,
ONE SUBSCRIPTION.

